

MICROELECTRONIC OPERATION AND UNIT TROUBLESHOOTING

Library	Service Literature
Product Section	Unitary
Product	Rooftop Lt. Comm.
Model	YK, TK, WK*
Literature Type	Maintenance
Sequence	3
Date	November 2000
File No.	SV-UN-RT-MICRO-M-3 11/00
Supersedes	New

Customer Property — Contains wiring, service, and operating instructions Please retain.

Models:

YK, TK*063-250

WK*063-200

Gas/Electric, Electric/Electric & Heat Pump 063 Through 250

General

This Maintenance Manual covers all YK, TK*063-250 and WK*063-200.

Important Note: *References made to components whose suffix is a 2 (e.g. CC2, SOV2, ODM2, CPR2, etc), apply to dual circuit units only. If your unit has only one circuit, ignore these references throughout the manual.*

⚠ WARNING : BODILY INJURY CAN RESULT FROM HIGH VOLTAGE ELECTRICAL COMPONENTS, FAST MOVING FAN DRIVES AND COMBUSTIBLE GAS. FOR PROTECTION FROM THESE INHERENT HAZARDS DURING INSTALLATION AND SERVICING, THE ELECTRICAL SUPPLY MUST BE DISCONNECTED AND THE MAIN GAS VALVE (IF APPLICABLE) MUST BE TURNED OFF. IF OPERATING CHECKS MUST BE PERFORMED WITH THE UNIT OPERATING, IT IS THE TECHNICIAN'S RESPONSIBILITY TO RECOGNIZE THESE HAZARDS AND PROCEED SAFELY.

IMPORTANT NOTE: *These units are equipped with an advanced electronic unitary control processor, (UCP) that provides service functions which are significantly different from conventional units. Refer to the **TEST MODES** and **START-UP PROCEDURES** before attempting to operate or perform maintenance on this unit.*

1. Preliminary Overview And Familiarization

a. Microelectronic Control Benefits	3
b. Microelectronic Control Features	3
c. Microelectronic Component Definitions	3
d. Pictorial Systems / Component Combinations	4
e. Installation Differences Microelectronic VS Electromechanical	5
f. Control Wiring Tables	6

SEQUENCE OF OPERATION

2. Mechanical Cooling Operation:

a. (TK's, WK's, & YK's)	6
b. Low Ambient Cooling Evaporator Defrost Control (EDC) Function	7

3. Economizer Cooling Operation

(TK's, WK's, & YK's):

a. Standard Dry Bulb	7
b. Reference Enthalpy	8
c. Comparative Enthalpy	8

4. Heating Operation:

a. Electric Heat	9
b. Mechanical And Electrical Heat	9
c. Mechanical Heat Defrost (Time & Temp.)	9
d. Mechanical Heat Defrost (Demand Defrost)	10
e. Emergency Heat	10
f. Gas Heat	10
g. Gas Heat Limit Control Operation, And Location (YK's)	11

Microelectronic Control Benefits

1. Many manufacturers are giving their products more functions, and increasing product reliability through the use of electronics.
2. Microcontrols provide superior space temperature control. Proportional / Integral control provides the best possible comfort level for your customer.
3. Microcontrols eliminate the need for additional accessories. Several time delay and equipment protection functions have been incorporated into the logic of the Microcontrols, ultimately optimizing system operation.
4. Since equipment protection and time delays are integral functions of the Microcontrol logic, several controls have been eliminated resulting in fewer components. This means fewer components to fail, and fewer to replace.
5. A complete line of Zone Sensor Modules (ZSM's) are available. All of the stand alone ZSM's are available with remote sensing capabilities, and space temperature averaging capabilities. The dual set point, and program-

5. Diagnostics And Troubleshooting:

a. Thermistor Resistance / Temperature Chart	11
b. Recommended Steps For Troubleshooting	11
c. Failure Status Diagnostic Sheet	12
d. Recommended Test Mode Procedure (Step Test)	13
e. Unit Test Mode Status Charts	14
f. Alternate Test Mode Procedures	15
g. Resetting Cooling Failures & Ignition Lockouts	15

6. Individual Component Test Procedures:

a. Zone Sensor Module (ZSM) Service Indicator	15
b. Zone Sensor Module (ZSM) Test Procedures	16
c. Unitary control Processor (UCP) Default Chart	17
d. Unitary Economizer Module (UEM) Test Procedures	18, 19
e. Defrost Module (DFM) Test Procedures	19, 20, 21
f. Conventional Thermostat Interface (CTI) Test Procedures	21, 22

7. System Troubleshooting Charts:

a. Electric / Electrics (TK's) Heat Pumps (WK's) Gas Electrics (YK's)	23, 24, 25, 26, 27
b. System Adaptive Operation Chart	28, 29, 30

8. Space Temperature Averaging

mable models are available with remote status panel indication.

6. Built in test mode, and on board diagnostics to aid in troubleshooting. "NO" special service tools are required.
7. Light commercial Microcontrols have been designed and tested around our proven design and reliability criteria, used in our automation controls.
8. Microelectronic controls in light commercial rooftops allow total ICS™ system selling.

Microelectronic Control Features

1. Low ambient start timer (LAST) function. Bypasses low pressure controls for 3 minutes when a compressor starts.
2. Anti short cycle timer (ASCT) function. Compressor operation is programmed for 3 minutes of minimum "ON" time, and 3 minutes of minimum "OFF" time. Enhances compressor reliability, and ensures proper oil return.

3. Delay between stages timer function. When combined with a standard Zone Sensor Module (ZSM), the Unitary Control Processor (UCP) provides a 90 second minimum "ON" delay for compressor staging.
4. Built in Fan Delay Relay (FDR) function. When the fan mode switch on the Zone Sensor Module (ZSM) is set in the auto position, the Unitary Control Processor (UCP) provides individual supply fan timing sequences for each system in heating and cooling. The Unitary Control Processor (UCP) provides different timing sequences for Heat Pumps, Gas Electrics, and Cooling only units, and all 3 systems use the same Unitary Control Processor (UCP).
5. Low ambient cooling to -18.0°C (0°F), with built in Evaporator Defrost Control (EDC) function. Utilizing time and temperature, instead of temperature alone.
6. Built in electric heat staging, provides a 90 second "ON" delay between resistance heat stages.
7. Compressor cycle rate minimization, extends compressor life expectancy. Minimizes damaging compressor in-rush current, and guards against short cycling.
8. Built in Heat Pump "**Smart Recovery**", saves your customer money. If the heat produced by the compressor(s) is making a recovery toward setpoint at a rate of at least -14°C (6°F) per hour, the electric heat is not turned on. A 9 minute stage up delay allows time for recovery to begin.
9. Built in "**Soft Start**" feature, when a heat pump defrost cycle is terminating, the outdoor motors are turned on for 5 seconds before de-energizing the switch over valves. "Soft Start" provides a smooth transition back to mechanical heating operation, minimizes noise associated with switch over valve operation, and greatly reduces stress on compressors associated with high pressure differential during defrost.
10. Demand defrost (063 and 073 only) measures heat pump outdoor ambient temperature with an outdoor air sensor (**OAS**) located near the outdoor coil. A second sensor located on the outdoor coil is used to measure the coil temperature. The difference between the ambient and the colder coil temperature is the difference or delta-T (DT) measurement. This delta-T measurement is representative of the operating state and relative capacity of the heat pump system. By measuring the change in delta-T, the need for defrost can be determined. The coil temperature sensor (**CTS**) also serves to sense outdoor coil temperature for termination of the defrost cycle.
11. Economizer preferred cooling allows fully integrated economizer operation. Under extreme low ambient cooling conditions, the compressor(s) can operate in conjunction with the economizer if actually needed. A 3 minute delay evaluates and verifies that the zone temperature is dropping faster than acceptable parameters. If so, compressor(s) will be enable to hold the zone temperature.
12. Free night setback allows the unit to enter an unoccupied mode by simply shorting across terminals 11 and 12 on the low voltage terminal board. The short can be achieved by a set of dry contacts or a time clock. Once this short has been made the unit will shut the economizer, go from continuous fan to auto fan operation, and set the temperature in the space back or up by minimum of -14°C (7°F). For example if you had your cooling set point at 23°C (74°F) then in the unoccupied mode the unit will be cooling to a minimum of 27°C (81°F). This option can't be used with programmable sensors or with an ICS™ system.
13. Low pressure cutouts on all compressors have been added to insure compressor reliability in a low refrigerant situations. The compressor(s) will lockout after four consecutive low pressure control trips during the compressor minimum 3 minute on time. The lockout will have to be manual reset as explained in this document.
14. Lead/Lag (Dual Circuit Units Only). Lead/Lag is a selectable configuration within the UCP which alternates the starting of the compressors between the two refrigeration circuits. To enable the Lead/Lag function, cut wire 52F (PR) which is connected to terminal J1-7 at the UCP. (Refer to the unit wiring diagram.) Each time the request for cooling is satisfied, the designated lead compressor switches. Upon Power-up Initialization, the control will default to the number one compressor. When a Conventional Thermostat Interface (CTI) is used, Lead/Lag is functional except during the test mode.

Microelectronic Component Definitions

1. Unitary Control Processor (UCP), is a standard component of the unit. This is the heart of the system, the computer and program reside in this module. The typical basic stand alone system will include the UCP and a Zone Sensor Module.
2. Zone Sensor Module (ZSM), is an accessory component and replaces a thermostat. It provides operator interface and the zone temperature sensor for the UCP. A complete line of ZSMs are available with various combinations of features. A ZSM is required for each system, unless using a CTI.
3. Unitary Economizer Module (UEM), is a standard component on the economizer accessory. This module provides the hardware necessary to connect the economizer accessory to the UCP.
4. Defrost Module (DFM), is a standard component on WK*100 - 200 Heat Pump models, and provides the temperature input to the UCP for the time and temperature defrost function. The Defrost Module (DFM) plugs into the UEM when an economizer is present.
5. (TCI) Communication Interface is an accessory component. This interface module is required to connect the system to an ICS™ BUILDING MANAGEMENT SYSTEM.
6. Conventional Thermostat Interface (CTI), is a field installed accessory component. This module can be used in special applications that require the installation of select electro-mechanical thermostats to interface with the UCP, instead of using a Zone Sensor Module (ZSM).

Pictorial Systems / Component Combinations

Basic Stand Alone System

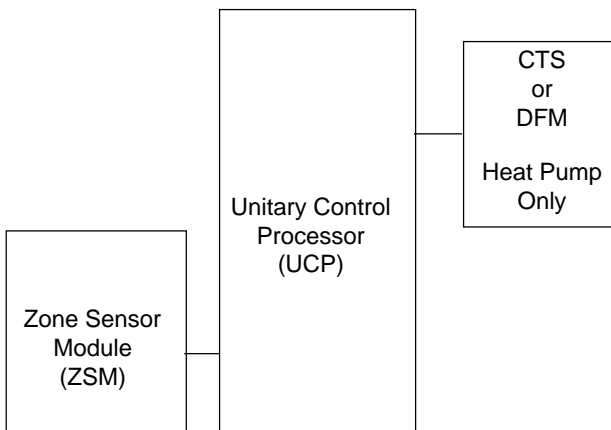

Stand Alone System With Economizer

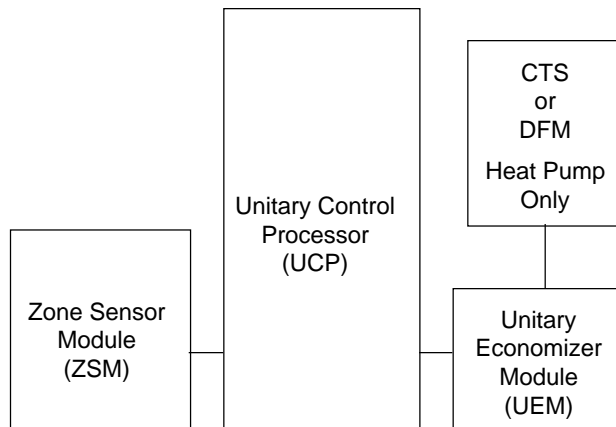

Stand Alone System With Conventional Thermostat

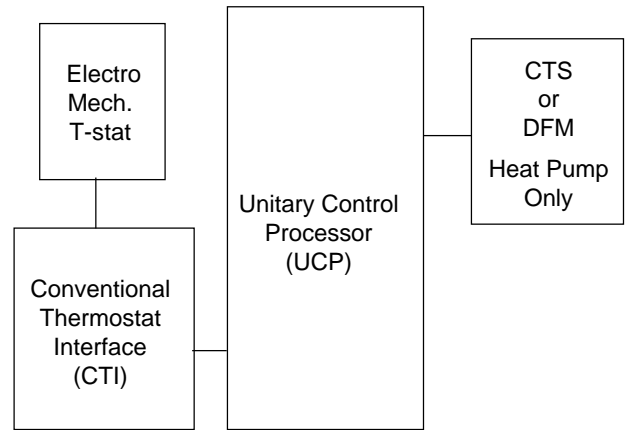

Stand Alone System With Conventional Thermostat and Economizer

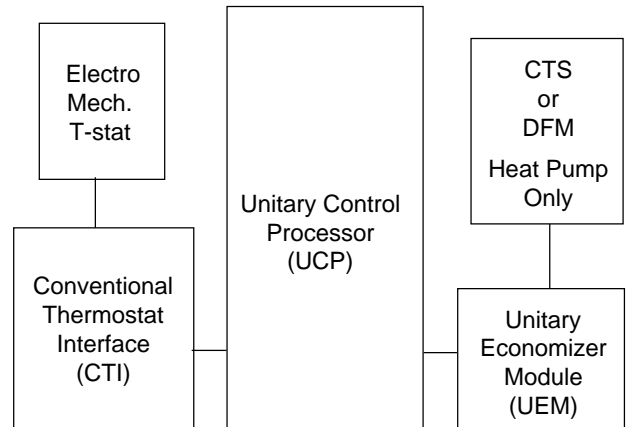

Basic Integrated Comfort™ System

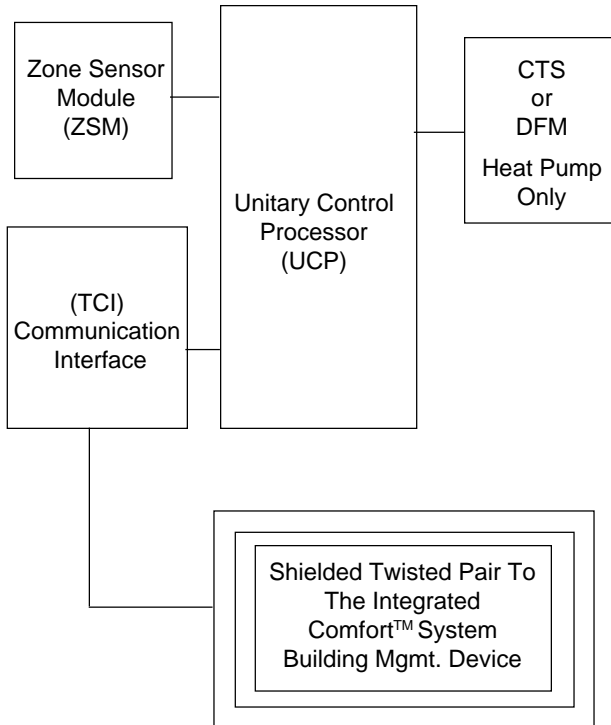

Integrated Comfort™ System With Economizer

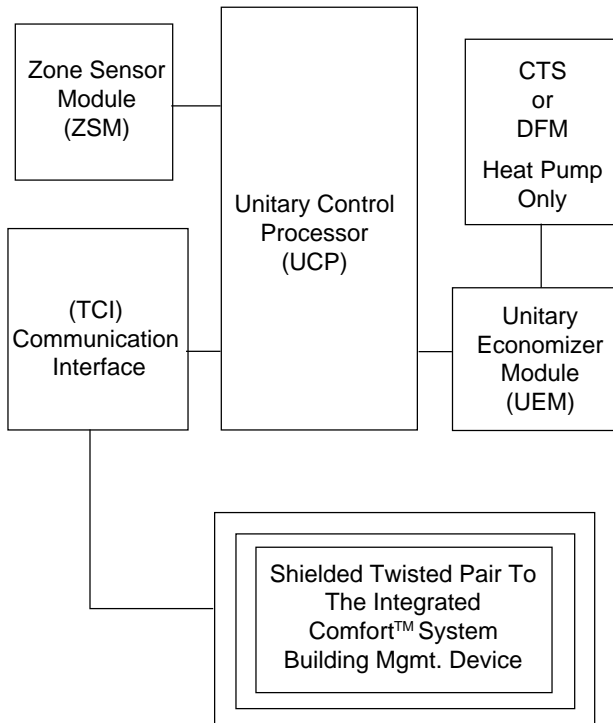

Installation Differences Microelectronic VS Electromechanical

There are very few differences in the installation of microelectronic control units. The basic mechanics are identical to electromechanical units. The differences are described below.

1. The biggest and most dramatic difference is that the industry standard terminal designations no longer exist. In other words, "R-G-Y-W-B" are no longer used. This is a very big change, but in reality it is a simplification. Terminal designations are now 1-2-3-4-5 etc.

The terminal designations on the Zone Sensor Modules (ZSMs) are identical to the terminal designations on the customer connection, or Low Voltage Terminal Board (LTB). No more wondering what zone sensor goes to what unit terminal.

Customer control wiring connections are as simple as: 1 to 1, 2 to 2, 3 to 3, 4 to 4, 5 to 5, and so on.

Example

Zone Sensor Module (ZSM) **Low Voltage Terminal Board (LTB)**

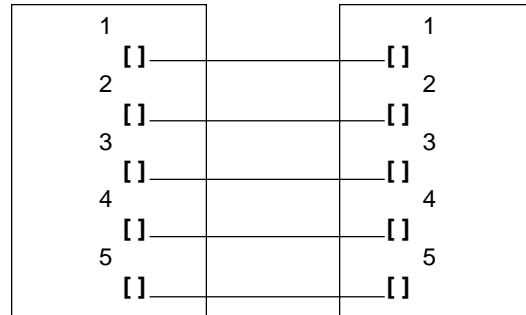

2. The only other installation difference occurs when an economizer is installed on a Heat Pump. In this case (on the 100 - 200) the economizer (UEM) must be placed in line between the Unitary Control Processor (UCP), and the Defrost Module.

On the 063 and 073 units, the economizer (UEM) must be placed in line between the (UCP) and the Coil Temperature Sensor (CTS).

All of the necessary polarized plugs are located in the unit control box, as part of the wiring harness.

Control Wiring Tables

Table 1 Zone Sensor Module (ZSM) to Low Voltage Terminal Board (LTB) and Remote Sensor to Zone Sensor Module (ZSM) Wire Type = Standard Thermostat Wire, solid conductor.

Wire Size (mm ²)	Maximum Wire Length (m)
0,25	50
0,5	75
0,75	100
1,0	200
1,5	300

Note: Total resistance must not exceed 5 Ohms, or ZSM calibration accuracy may exhibit problems.

Table 2 Remote Sensor to Programmable Zone Sensor Module (ZSM)

Type	= Shielded Twisted Pair of Conductors.
Specification	= 18-gauge / Beldon 8760 or equivalent.
Length	= 300m (1,000 feet), or less.

Table 3 Integrated Comfort™ System to (TCI) Communication Interface

Type	= Shielded Twisted Pair of Conductors.
Specification	= 18-gauge / Beldon 8760 or equivalent.
Length	= 1500m (5,000 feet), or less.

Mechanical Cooling Sequence Of Operations (TK / WK / YK)

Time delays are built in as described below. They increase reliability by protecting the compressor, and by maximizing efficiency of unit performance.

Unit Start-Up

Each time power is applied to the system, the UCP performs internal self-diagnostic checks. It determines the system configuration (including installed options), and prepares for control of this configuration. It also checks itself for proper internal functioning. Within one second of start-up, the UCP system indicator (a red light on the UCP board) glows if programming is intact and functional.

On units with the optional economizer, the damper(s) is driven open for 15-20 seconds, and then closed for approximately 90 seconds. This assures proper damper calibration.

Cooling Operation/Mechanical Compressor Cycle (For units without Economizer Operation)

Note: Some units have only one circuit.

Note: The compressors are controlled to a minimum run time of 3 minutes, and once shut off will not start again for 3 minutes.

On Heat Pump models (WC's), the UCP keeps the Switch Over Valves (SOV1 & SOV2) energized, whenever the unit is in the cooling mode.

When mechanical cooling is required, the UCP energizes the Compressor Contactor (CC1) coil. When the CC1 contacts close, the Compressor CPR1 and Outdoor Fan Motor(s) (ODM1 / ODM2) start. ODM2 cycles off/on based on outdoor ambient temperature measured by the Outdoor Air Sensor (OAS); "OFF" if temperature falls below 16°C (±1°C) [60° (±2°)F], and "ON" if temperature rises above 18°C (±1°C) [65° (±2°)F]. CPR1 cycles on and off as required by cooling demands.

If additional cooling is required with CPR1 running, the UCP energizes the 2nd compressor contactor (CC2) to bring on CPR2.

Note: A minimum of 10 seconds must have elapsed since energizing CC1.

While CPR1 continues to run, CPR2 cycles on/off as needed to meet cooling requirements.

Note: When Lead/Lag is enabled, each time the designated lead compressor is shut off due to the load being satisfied, the lead compressor switches.

If the indoor fan is set to "AUTO", the UCP energizes the Indoor Fan Contactor (F) coil approximately one second after energizing the compressor contactor. The Indoor Fan Motor (IDM) starts when contacts of F close. When the cooling cycle is complete and CC1 is de-energized, the UCP keeps the F coil energized for 60 seconds of additional IDM operation to enhance unit efficiency.

Low Ambient Cooling Evaporator Defrost Control (EDC) Function

The Evaporator Defrost Control (EDC) function provides standard low ambient cooling down to -18°C (0°F), at this temperature the equipment is capable of providing approximately 60% of the mechanical cooling capacity. During low ambient operation compressor run time is counted and accumulated by the UCP. Low ambient operation is defined as 13°C (55°F) for single condenser fan units, and 4°C (40°F) for dual condenser fan units.

When accumulated compressor run time reaches approximately 10 minutes, an evaporator defrost cycle is initiated. An evaporator defrost cycle lasts approximately 3 minutes, this matches the compressor 3 minute minimum OFF time.

When an evaporator defrost cycle occurs, the compressors are turned off and the indoor fan motor continues to run. After completing an evaporator defrost cycle the unit returns to normal operation, and the compressor run time counter is reset to zero. Economizer operation is not affected by an evaporator defrost cycle.

This function can be tested, or temporarily operated in the event of an Outdoor Air Sensor (OAS) failure, by following the instructions below.

1. Electrically remove the Outdoor Air Sensor (OAS) from the circuit, by cutting the wires at the splice caps in the lower right hand corner of the control box.
2. Insert a 1/4 watt resistive value in place of the OAS to simulate a low ambient condition (33K to 75K Ohms). This will simulate an outdoor air temperature between -15°C to 0°C (5°F to 32°F). Place unit in cooling mode, and set cooling setpoint to 10°C (50°F).
3. Result = Evaporator Defrost Control (EDC) function will be activated, and compressor run time counter will begin counting and accumulating compressor run time. On dual condenser fan units, Outdoor Motor (ODM2) will be turned "OFF" since the UCP is sensing a low ambient condition. After approximately 10 minutes, a defrost cycle will be initiated.

In the event of an OAS failure, the resistor above may be left in the circuit to provide temporary low ambient cooling until the OAS can be replaced.

If 100% mechanical cooling capacity at -18°C (0°F) is required, the Outdoor Air Sensor (OAS) must be permanently disconnected, and an additional low ambient control device must be selected. Contact Application Engineering in Clarksville, Tn.

Dry Bulb Economizer Cooling Operation

Standard economizer dry bulb change over temperature is field selectable to three outdoor temperature 13, 16 18°C (55, 60 and 65 degrees F.). See table for switch settings.

Standard Economizer Dry Bulb Switch Settings

Switch 1	Switch 2	Temperature Setting
OFF	OFF	(Factory set) * 16°C (60°F)
OFF	ON	13°C (55°F)
ON	OFF	18°C (65°F)
ON	ON	Not used

For these switches: OFF - is towards the edge of board
On - is towards the center of board
* Default setting

The economizer option allows cooling with outdoor air when its temperature is below 16°C (±1°C) [60°(±2°)F] (Factory Setting). This air is drawn into the unit through modulating dampers. The UCP signals the Economizer Actuator (ECA) to open/close the damper(s) from minimum position to full open, cooling the space to 1.5°C. below the cooling set-point. If the Supply Air Sensor (SAS) senses that supply air is too cold, the dampers modulate closed until supply air temperature rises, or until dampers close to their minimum position.

The economizer allows fully integrated cooling operation. In extreme cooling requirement periods, the compressor(s) can operate in conjunction with the economizer if needed to satisfy cooling setpoint. The 3 minute delay evaluates if the temperature is dropping faster than acceptable and will energize compressor(s) as needed to maintain adequate zone control.

If a power exhaust accessory is present, the power exhaust fan motor is energized whenever the economizer damper is at a position greater than 25% of the actuator stroke.

During simultaneous economizing and mechanical compressor cooling, the UCP continues to modulate the ECA to keep the supply air temperature in the 7 - 13°C (45-55°F) range.

NOTE: Outdoor Air Sensor (OAS) standard on all Micro-control units. Supply Air Sensor (SAS) standard on economizer accessory.

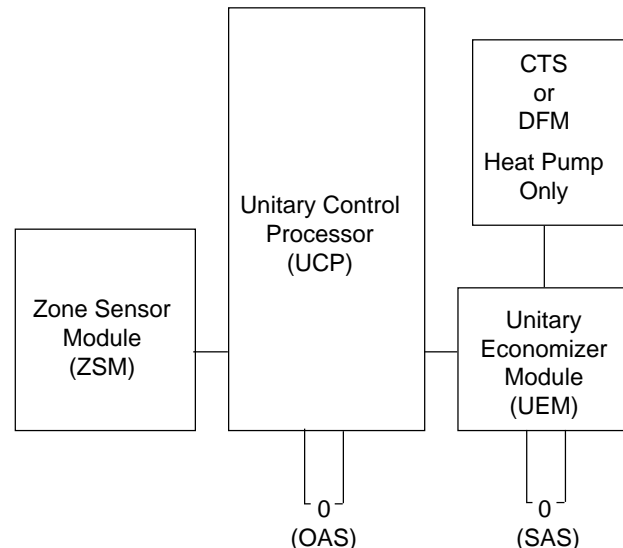

Reference Enthalpy Economizer Cooling Operation

Reference enthalpy is accomplished by using the Outdoor Humidity Sensor (OHS) along with the economizer option. The reference enthalpy is field selectable to one of four standard enthalpies, the same settings that we've grown accustomed to in the past with electromechanical units.

Reference enthalpy is similar to single enthalpy control. If the outdoor air enthalpy is greater than the selected reference enthalpy, the economizer will not operate and the damper will not open past the minimum position setting.

If the outdoor air enthalpy is less than the reference enthalpy, the dampers will modulate to maintain a 7°C to 13°C (45° to 55°F) supply air temperature, cooling the space to 1.5°C below the zone temperature set point. With reference enthalpy control, no economizer operation is allowed if the outdoor air temperature is above 24°C (75°F).

Select the desired Reference Enthalpy using the chart below.

Switch 1	Switch 2	Selected Enthalpy kJ/kg	Standard Setting
ON	ON	65 kJ/kg	A
ON	OFF	58 kJ/kg	B
OFF	ON	51 kJ/kg	C (Default)
OFF	OFF	44 kJ/kg	D (Factory)

The reference enthalpy selection switches are located on the Unitary Economizer Module, and are shipped factory set at "D", which is the most comfortable setting. If any failures occur in this switching circuit, the Reference Enthalpy will default to setting "C".

If the Outdoor Humidity Sensor (OHS), or the Unitary Economizer Module's (UEM's) input for this sensor were to fail, the economizer will operate using Dry Bulb Economizer Cooling Operation.

NOTE: Outdoor Air Sensor (OAS) standard on all Micro-control units. Supply Air Sensor (SAS) standard on economizer accessory.

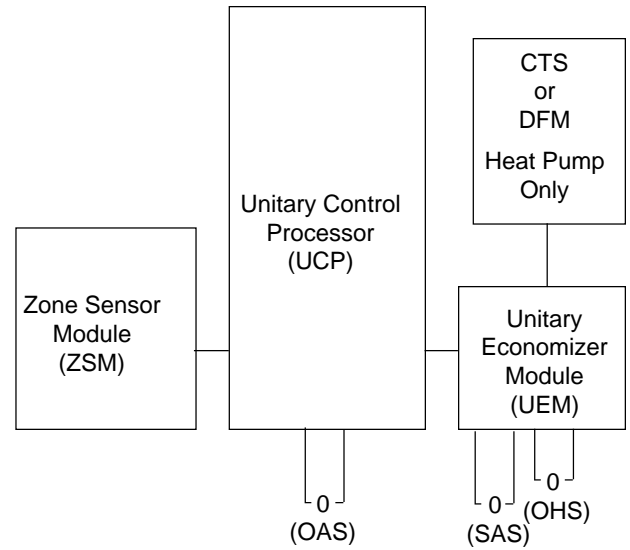

Comparative Enthalpy Economizer Cooling Operation

Comparative Enthalpy is accomplished by using the Outdoor Humidity Sensor (OHS), Return Humidity Sensor (RHS), and the Return Air Sensor (RAS), along with the economizer option.

Comparative Enthalpy is similar to differential enthalpy, which we use in electromechanical units. If the outdoor air enthalpy is greater than the return air enthalpy, the economizer will not operate and the damper will not open past the minimum position setting. The economizer will not operate at outdoor air temperatures above 24°C (75°F).

If the outdoor air enthalpy is less than the return air enthalpy, the dampers will modulate to maintain a 10°C to 13°C (50° to 55°F) supply air temperature, cooling the space to 1.5°C below the zone temperature set point.

If the Return Humidity Sensor (RHS), the Return Air Sensor (RAS), or both fail, the economizer uses reference enthalpy.

NOTE: Outdoor Air Sensor (OAS) standard on all Micro-control units. Supply Air Sensor (SAS) standard on economizer accessory.

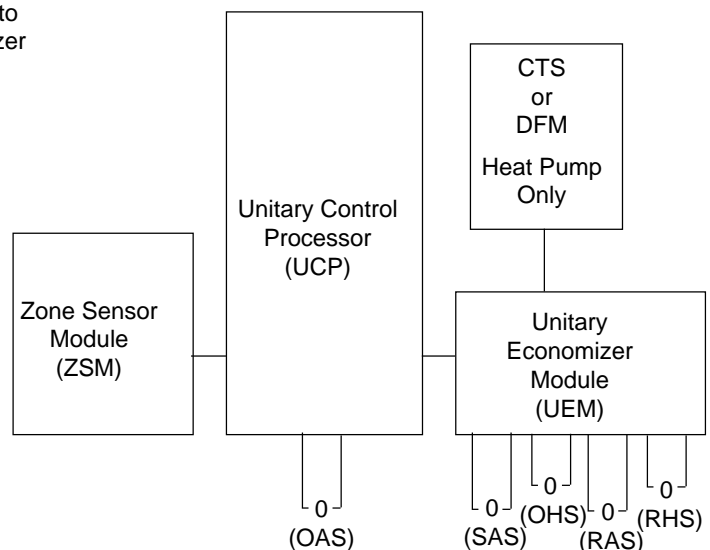

Electric Heat Sequence Of Operations (TK)

Units with Single Stage Electric heat

When heat is required, the UCP initiates a heating cycle by energizing the electric heat contactor (AH).

Note: The UCP has a built in 10 second delay between electric heat stages timing function. A minimum of 10 seconds must have elapsed since last power-up or since AH was last energized.

When the AH contacts close, the electric heater bank is energized, provided the element temperature limits are closed. The UCP will cycle heat on and off as required to maintain zone temperature.

Units with Two Stage Electric heat. When heat is required, the UCP initiates first stage heating by energizing the electric heat contactor AH or (AH + CH).

Note: A minimum of 10 seconds must have elapsed since last power-up or since AH/CH was last energized.

When the contacts close, the first stage electric heater bank(s) is energized, provided the element temperature limits are closed. The UCP will cycle first stage heat on and off as required to maintain zone temperature. If first stage cannot satisfy the heat requirement, the UCP energizes second stage electric heat contactor(s) BH or (BH + DH).

Note: A minimum of 10 seconds must have elapsed since energizing stage one (AH/CH), or last de-energizing stage two (BH/DH).

Closing of the BH(DH) contactor(s) energizes the second stage electric heater bank(s), provided the element temperature limits are closed. The UCP cycles second stage electric heat off/on as required to maintain zone temperature, while also keeping stage one heat energized. When the Indoor Fan is set to "AUTO", the UCP energizes the F coil approximately one second before energizing the electric heat contactor(s). The IDM starts when the contacts of F close. When the heating cycle is complete, the UCP de-energizes F at the same time as the electric heat contactor(s) AH(BH,CH,DH).

Mechanical And Electric Heat Sequence Of Operations (WK)

Note: Some units have only one circuit.

When heating is required, the UCP energizes both compressors, approximately one (1) second apart, and the indoor fan.

Note: The Switch Over Valves are de-energized when the unit is in heat mode.

When CC1 & CC2 contacts close, CPR1 & CPR2 start along with ODM1 & ODM2. During the heating cycle, ODM2 does not cycle on/off based on outdoor air temperature, as it does in the cooling cycle.

The UCP will cycle the mechanical heating, CPR1 & CPR2 to maintain the zone temperature. Upon completion of the heating cycle, the UCP de-energizes the Compressor Contactors (CC1 & CC2). If the fan mode is in the "AUTO" position, the F coil is de-energized approximately one (1) second after the compressors.

Every nine minutes after the mechanical heating cycle starts, the UCP checks the zone temperature to see if the temperature is rising sufficiently (at least 6° F per hour).

If auxiliary electric heat accessory is installed, and mechanical heating cannot satisfy the demand, the UCP energizes first stage electric heat contactor(s) AH or AH + CH. Their contacts close to energize the first stage electric heater banks, provided the element temperature limits are closed.

If mechanical heating and first stage auxiliary heat cannot satisfy the demand, the UCP energizes second stage auxiliary heat contactor(s) BH or BH + DH, provided a minimum of 10 seconds have elapsed since AH or AH + CH were energized. When the electric heat contactors BH or BH + DH close, the second stage electric heater banks are energized, provided the element temperature limits are closed.

The UCP continues to check each nine minutes, and eliminates auxiliary electric heat as soon as it determines that mechanical heat is sufficient ("Smart Recovery").

Mechanical Heat Defrost (Time & Temp.) Sequence Of Operations (WK) 100, 125-200 only

After the compressors have accumulated the run time selected on the Defrost Module (DFM), and the Defrost Temperature Switch (DT) closes, the UCP initiates an outdoor coil defrost. During the defrost cycle the Switch Over Valves (SOV1 & SOV2) are energized, the Compressors (CPR1 & CPR2) remain on, and the Outdoor Fan Motors (ODM1 & ODM2) are turned off. (If the unit is equipped with auxiliary electric heat, these elements are energized if not already on.) The defrost cycle ends when the DT changes to the "open" state, after approximately 10 minutes of defrost, or the high pressure control on either compressor opens. (Opening of the HPC1 or HPC2 does not cause a "cool fail" and lockout of the compressor during defrost as it does during mechanical heating and cooling.) At the end of the defrost cycle, the Outdoor Fan Motors (ODM1 & ODM2) are turned on for 5 seconds before de-energizing the Switch Over Valves (SOV1 & SOV2).

Mechanical Heat Defrost (Demand Defrost) Sequence Of Operations (WC) 063 thru 073 Only

Whenever the Unitary Control Processor **UCP** is powered with 24 V.A.C. and a heating cycle has been operating for 30 minutes, the UCP will automatically initiate a defrost cycle. Performance data gathered during this cycle sets the stage for the learning process to begin. Upon termination of the above cycle the UCP begins monitoring the Outdoor (OD) ambient temperature and the coil temperature. From these measurements the current ΔT (OD Ambient - coil temp.) is calculated. After a pre-determined length of time the current ΔT value is stored in memory. Using the stored value, the UCP will then calculate an initiate value. The UCP continues to monitor the ΔT and compares it to the calculated initiate value. In order for defrost to occur the OD Temperature must be below 11°C (52°F), the coil temperature below 10°C (33°F) and the ΔT must exceed the controls current calculated value. After the actual ΔT reaches the calculated value the defrost cycle will be initiated. During the defrost cycle the Switch Over Valve(s) (SOV1 & SOV2) are energized, the compressor(s) (CPR1 & CPR2) remain on, and the Outdoor Fan Motor (ODM) is turned off. (If the unit is equipped with auxiliary electric heat, these elements are energized if not already on.) The defrost cycle ends when the Defrost Termination Temperature (DTT) = Outdoor Temperature (ODT) + 8°C (47°F). The DTT will be no less than 14°C (57°F), and no more than 22°C (72°F), or the high pressure control (073 single compressor only) on the compressor opens. (Opening the HPC does not cause a “cool fail” and lockout of the compressor during defrost as it does during mechanical heating and cooling.) At the end of the defrost cycle, the Outdoor Fan Motor (ODM) is turned on for 5 seconds before de-energizing the Switch Over Valve(s) (SOV1 & SOV2).

Emergency Heat Sequence Of Operations (WK)

(For units with auxiliary electric heat accessory installed)

If heat is required in the zone and the unit mode is set to “EM HEAT”, the UCP will energize the first stage electric heat contactor(s) AH or AH + CH.

Note: The UCP has a built in 10 second delay between electric heat stages timing function. A minimum of 10 seconds must have elapsed since last power-up or since AH was last energized.

Their contacts close to energize the first stage electric heater banks, provided the element temperature limits are closed. The UCP cycles the first stage on/off as required to maintain zone temperature.

Note: A minimum of 10 seconds must have elapsed since last power-up, or since AH or AH + CH were last de-energized.

If the first stage of electric heat cannot satisfy demand, the UCP energizes the second stage electric heat contactor(s) BH or BH + DH, (provided a minimum of 10 seconds have elapsed since stage one was energized). Their contacts close to energize the second stage electric heater banks, provided the element temperature limits are closed. The UCP cycles the second stage on/off as required to maintain zone temperature, while keeping stage one energized.

The UCP continues to cycle on electric heat, without the compressors, to maintain zone temperature as long as the unit mode is set to “EM HEAT”.

When the Indoor Fan is set to “AUTO”, the UCP energizes the F coil approximately one second before energizing the electric heat contactor(s). The IDM starts when the contacts of F close. When the heating cycle is complete, the UCP de-energizes F at the same time as the electric heat contactor(s) AH(BH,CH,DH).

Gas Heat Sequence Of Operations (YK)

When heating is required, the UCP initiates the heating cycle by energizing the K5 relay coil on the UCP, the heat relay (H), and the ignition control module (IGN). The H contacts close to supply power to the K5 relay, and the K5 normally open contacts close to energize the high speed windings of the combustion fan motor (CFM).

Note: After a 60 second delay, the K5 relay coil is de-energized, and the CFM's low speed windings are energized through the K5 relay's normally closed contacts.

The **IGN** starts the ignition process by preheating the hot surface ignition probe (**IP**) for 30 seconds. After preheat of the **IP**, the Gas Valve (**GV**) is energized up to 7 seconds to ignite the burner. When the burner lights, the **IP** is de-energized and then functions as a flame sensor.

If the burner fails to ignite, the ignition module will attempt two retries. At the start of each ignition retry, the green LED will flash and the red LED will flash for five seconds before locking out. An **IGN** lockout can be reset by:

1. Opening and closing the main power disconnect switch,
2. By switching the “Mode” switch on the zone sensor to “OFF” and then to the desired position.
3. Allowing the ignition control module to reset automatically after one hour. Refer to the “Ignition Control Diagnostics” section for the LED diagnostic definitions.

If the fan is set to “AUTO”, the **UCP** energizes the Fan Contactor (**F**) 30 seconds after initiation of the heat cycle. When the **F** contacts close, the **IDM** starts. For units with automatic 2 - speed fan switching, the fan runs in high speed.

If the space temperature remains below the heating set point, the UCP energizes the K5 coil, provided a minimum of 10 seconds have elapsed since initiating the heating cycle. This energizes the high speed windings of the CFM through the normally open contacts of the K5 relay, delivering second stage heat capacity.

When the space temperature rises above the heating set point, the UCP de-energizes K5, H, and IGN, terminating the heat cycle. The F coil remains energized for an additional 90 seconds, providing the fan mode switch is set to "AUTO".

Gas Heat Limit Control Operation And Location (YK)

Both of the limits are automatic reset controls. The high limit cutout (TCO1) protects against abnormally high supply air temperature, and the fan failure limit (TCO2) protects against abnormally high heat build up if the IDM fails, or due to excessive TCO1 cycling. These controls are electrically wired in series, and will signal the UCP if a failure occurs, in which case the UCP will de-energize K5, H, and IGN, and also energize the F coil. This will set a heat fail diagnostic which is discussed later in this manual.

TCO1 is located in the bottom right corner of the burner compartment on both downflow and horizontal units. TCO2 is located on the IDM partition panel; below and to the right of the blower housing on downflow units. On horizontal units, TCO2 is located on the IDM partition panel above the blower housing.

Thermistor Resistance / Temperature Chart (Temperature VS resistance coefficient is Negative)

This chart is used on all thermistors in the Microelectronic Controls.

Degrees C	Degrees F	Nominal Resistance
-29°	-20°	170.1 K - Ohms
-26°	-15°	143.5 K - Ohms
-23°	-10°	121.4 K - Ohms
-21°	- 5°	103.0 K - Ohms
-18°	0°	87.56 K - Ohms
-15°	5°	74.65 K - Ohms
-12°	10°	63.80 K - Ohms
- 9°	15°	54.66 K - Ohms
- 7°	20°	46.94 K - Ohms
- 4°	25°	40.40 K - Ohms
- 1°	30°	34.85 K - Ohms
2°	35°	30.18 K - Ohms
4°	40°	26.22 K - Ohms
7°	45°	22.85 K - Ohms
10°	50°	19.96 K - Ohms
13°	55°	17.47 K - Ohms
16°	60°	15.33 K - Ohms
18°	65°	13.49 K - Ohms
21°	70°	11.89 K - Ohms
24°	75°	10.50 K - Ohms
27°	80°	9.297 K - Ohms
29°	85°	8.247 K - Ohms
32°	90°	7.330 K - Ohms
35°	95°	6.528 K - Ohms
38°	100°	5.824 K - Ohms

Recommended Steps For Troubleshooting

Step 1. DO NOT disconnect unit power with disconnect switch, or diagnostic & failure status information will be lost.

Step 2. Utilizing the porthole in the lower left hand corner of the control box dead front panel, verify that the LED on the UCP is burning continuously. If LED is lit, go to Step 4.

Step 3. If LED is not lit, verify presence of 24 VAC between LTB-16 and LTB-20. If 24 VAC is present, proceed to Step 4. If 24 VAC is not present, test unit primary voltage, test transformer (TNS1) and fuse, test fuse (F1) in upper right hand corner of UCP. Proceed to Step 4 if necessary.

Step 4. Utilizing the "Failure Status Diagnostic Sheet," test the following: System status, Heating status, and Cooling status. If a Heating failure, a Cooling failure, or both are indicated, follow instructions in "Failure Status Diagnostic Sheet". If a System failure is indicated, proceed to Step 5. If no failures are indicated, proceed to Step 6.

Step 5. If a System failure is indicated, re-check Steps 2 and 3. If the LED is not lit in Step 2, and 24 VAC is present in Step 3, the UCP has failed. Replace UCP.

Step 6. If no failures are indicated, place the system in the test mode, utilizing the "Recommended Test Mode Procedure" on page 13. This procedure will allow you to test all of the UCP's on board outputs, and all of the off board controls (relays, contactors, etc.) that the UCP outputs energize, for each respective mode. Proceed to Step 7.

Step 7. Step the system through all of the available modes, and verify operation of all outputs, controls, and modes. If a problem in operation is noted in any mode, you may leave the system in that mode for up to one hour while troubleshooting. Refer to sequence of operations for each mode, to assist in verifying proper operation. Make repairs if necessary, and proceed to Steps 8, and 9.

Step 8. If no abnormal operating conditions appear in the test mode, exit the test mode by turning the power off at the service disconnect switch.

Step 9. Refer to "Individual Component Test Procedures" page 16, if other microelectronic components are suspect.

Failure Status Diagnostic Sheet

Status is checked by using one of the following two methods:

Method 1. If your Zone Sensor Module (ZSM) is equipped with remote panel indication (LED's), you can check unit status in the space. If ZSM does not have LED's, use Method 2. The LED descriptions are listed below.

LED 1.

SYSTEM = ON continuously during normal operation.
OFF if System failure occurs, or LED fails.
Blinks on & off continuously if in test mode.

LED 2.

HEAT = ON continuously when heat cycle is operating.
OFF when heat cycle terminates, or LED fails.
Blinks on & off to indicate a Heating failure.

LED 3.

COOL = ON continuously when cool cycle is operating.
OFF when cool cycle terminates, or LED fails.
Blinks on & off to indicate a Cooling failure.

LED 4.

SERVICE = ON continuously indicates a clogged filter
(when Clogged Filter Switch is installed).
OFF during normal operation.

Below is the complete listing of failure indication causes.

System failure

Test voltage between terminals 6 and 9 on ZSM, should read approximately 32 VDC. If voltage is present, LED has failed. If no voltage is present, this indicates a System failure. (See page 11 "Recommended Steps For Troubleshooting" Step 5)

Heating Failure

1. TCO1 or TCO2 has opened (YK's only).
2. ZSM mode switch is in Emergency Heat position (WK's only).

Cooling Failure

1. Cooling set point (slide pot) on ZSM has failed. See ZSM test procedures, page 16.
2. Zone temperature thermistor ZTEMP on ZSM failed. See ZSM test procedures, page 11.
3. CC1 or CC2 24 VAC control circuit has opened, check CC1 & CC2 coils, and HPC1 and HPC2.
4. LPC1 or LPC2 has opened during 3 minute minimum on time on 4 consecutive compressor starts, check LPC1 or LPC2 by testing voltage between J2-2 and J2-3 terminals on the UCP and ground. If 24 VAC is present LPC1 and LPC2 have not tripped. If 0 VAC is present they have tripped.

Service Failure

1. AFF has closed unit will not operate, check motors and belts.
2. CFS has closed, check filters.

Simultaneous Heating and Cool Failure

This failure can be indicated on heat pumps (WK's), meaning a possible defrost problem exists. On 085 thru 200 units see DFM test procedures, pages 19 and 20.

On 063 thru 073 units with demand defrost, the following problems will cause a 10 minute default defrost after each 30 minutes of compressor run time. See page 27, symptom W of the troubleshooting chart.

Coil Temperature Sensor (CTS) Failure
Outdoor Air Sensor (OAS) Failure
Low Delta T for 2 Hours
10 Consecutive Defrosts Terminated by Time
16 Consecutive High Delta T's After Defrost

Method 2. The second method for determining failure status is done by checking voltage readings at the unit Low Voltage Terminal Board (LTB). The system indication descriptions are listed below.

Note: Voltages listed below are approximate.

1. **SYSTEM** = Measure voltage between terminals LTB-9, & LTB-6.
Normal Operation = approximately 32 VDC
System Failure = less than 1 VDC, approximately 0.75 VDC
Test Mode = alternates between 32 VDC & 0.75 VDC
2. **HEAT** = Measure voltage between terminals LTB-7, & LTB-6.
Heat Operating = approximately 32 VDC
Heat Off = less than 1 VDC, approximately 0.75 VDC
Heating Failure = alternates between 32 VDC & 0.75 VDC
3. **COOL** = Measure voltage between terminals LTB-8, & LTB-6.
Cool Operating = approximately 32 VDC
Cool Off = less than 1 VDC, approximately 0.75 VDC
Cooling Failure = alternates between 32 VDC & 0.75 VDC
4. **Service** = Measure voltage between terminals LTB-10, & LTB-6.
Clogged Filter = Approximately 32 VDC.
Normal = Less than 1 VDC, approximately 0.75 VDC
Fan Failure = Alternates between 32 VDC & 0.75 VDC.

Note: To read failure status at the LTB with LED's, purchase a ZSM. Fitted with alligator type jumper wires connected to terminals 6 through 10, it can be connected to the unit LTB terminals 6 through 10, providing quick status information at the unit.

Recommended Test Mode Procedure (Step Test)

Step 1.

Utilizing the port hole in the lower left hand corner of the of the control box dead front panel, verify that the LED on the UCP is burning continuously.

Step 2.

Initiate the test mode by shorting across the "TEST" terminals on the unit's Low Voltage Terminal Board (LTB) for two to three seconds, and then removing the short. The LED on the UCP will blink indicating the unit is in the test mode, and the indoor fan motor (IDM) is turned on (STEP 1). See test mode table.

Note: The unit may be left in any step for up to one hour to allow for troubleshooting. If left in any one mode, after approximately one hour, the UCP will exit the test mode and return to zone sensor control.

Step 3.

To step into the next mode, short across the "TEST" terminals, and remove the short. See test mode table.

Note: The UCP will skip the steps marked with *, or **, if they are not a feature or accessory on this unit.

Step 4.

Exit the test mode by cycling unit power with the disconnect switch (off & on), or by stepping through the test steps, until UCP's LED glows continuously.

TEST MODE TABLE

STEP	MODE	LED	OHMS
None	Normal Oper.	ON	N/A
1	I.D. Fan ON	BLINK	2.2K
2 *	Open Econ.	BLINK	3.3K
3	Cool 1	BLINK	4.7K
4	Cool 2	BLINK	6.8K
5	Heat 1	BLINK	10K
6 *	Heat 2	BLINK	15K
7 *	Heat 3	BLINK	22K
8 **	Defrost	BLINK	33K
9 **	EM HEAT	BLINK	47K
None	Normal Oper.	ON	N/A

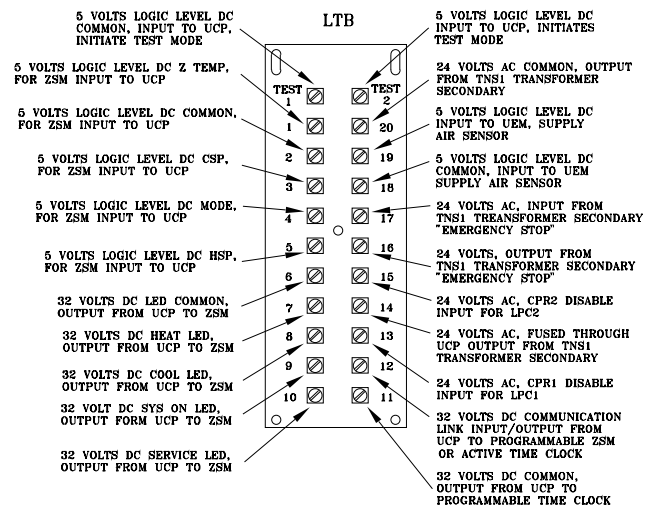

Unit Test Mode Status Charts for:

Electric/Electric Units

Step	Mode	IDM	Econ	CPR1	CPR2	HT1	HT2	ODM1	ODM2
1	Fan On	On	Min	Off	Off	Off	Off	Off	Off
2 *	Econ.	On	Open	Off	Off	Off	Off	Off	Off
3	Cool 1	On	Min	On	Off	Off	Off	On	***
4	Cool 2	On	Min	On	On	Off	Off	On	***
5 *	Heat 1	On	Min	Off	Off	On	Off	Off	Off
6 *	Heat 2	On	Min	Off	Off	On	On	Off	Off
7 *	Heat 3	Not Applicable on Electric/Electric Units.							
8 **	Defrost	Not Applicable on Electric/Electric Units.							
9 **	Em Heat	Not Applicable on Electric/Electric Units.							

* With Optional Accessory

** With Heat Pump

*** "Off" If temperature falls below 16° (±1)C [60° (±2°)F], "On" if temperature rises above 18° (±1°)C [65° (±2°)F].

Note: Steps for optional accessories and modes not present in unit, will be skipped. Steps 7, 8 & 9 are not applicable on the Electric/Electric units.

Heat Pump Units

Step	Mode	IDM	Econ	CPR1	CPR2	AUX HT1	AUX HT2	SOV	ODM1	ODM2
1	Fan On	On	Min	Off	Off	Off	Off	Off	Off	Off
2 *	Econ.	On	Open	Off	Off	Off	Off	Off	Off	Off
3	Cool 1	On	Min	On	Off	Off	Off	On	On	***
4	Cool 2	On	Min	On	On	Off	Off	On	On	***
5	Heat 1	On	Min	On	On	Off	Off	Off	On	On
6 *	Heat 2	On	Min	On	On	On	Off	Off	On	On
7 *	Heat 3	On	Min	On	On	On	On	Off	On	On
8 **	Defrost	On	Min	On	On	On	On	On	Off	Off
9 **	Em Heat	On	Min	Off	Off	On	On	Off	Off	Off

* With Optional Accessory

** With Heat Pump

*** "Off" If temperature falls below 16° (±1)C [60° (±2°)F], "On" if temperature rises above 18° (±1°)C [65° (±2°)F].

Note: Steps for optional accessories and modes not present in unit, will be skipped.

Gas/Electric Units

Step	Mode	IDM	Econ	CPR1	CPR2	HT1	HT2	ODM1	ODM2
1	Fan On	On	Min	Off	Off	Off	Off	Off	Off
2 *	Econ.	On	Open	Off	Off	Off	Off	Off	Off
3	Cool 1	On	Min	On	Off	Off	Off	On	***
4	Cool 2	On	Min	On	On	Off	Off	On	***
5	Heat 1	On	Min	Off	Off	On	Off	Off	Off
6	Heat 2	On	Min	Off	Off	On	On	Off	Off
7	Heat 3	Not Applicable on Gas/Electric Units.							
8 **	Defrost	Not Applicable on Gas/Electric Units.							
9 **	Em Heat	Not Applicable on Gas/Electric Units.							

* With Optional Accessory

** With Heat Pump

*** "Off" If temperature falls below 16° (±1)C [60° (±2°)F], "On" if temperature rises above 18° (±1°)C [65° (±2°)F].

Alternate Test Mode Procedures (Auto Cycle Test, and Resistance Test)

There are 2 alternate methods for operating the unit in the test mode, the **Auto Cycle Test** and the **Resistance Test**.

Method 1. Auto Cycle Test.

This test mode is the most useful during initial system start up. The entire duration of the test will last from 90 -270 seconds (depending on the unit, and accessories installed). See Test Mode Table page 13.

Step 1.

Initiate the Auto Cycle Test by installing a jumper across the “**TEST**” terminals on the unit’s Low Voltage Terminal Board (LTB). The LED on the UCP will begin to blink, indicating the unit is in the test mode. The unit will cycle through the test steps in sequence, one time, changing test steps every 30 seconds. See Test Mode Table page 13.

Note: The UCP will skip the steps marked with *, or **, if they are not a feature or accessory on this unit.

Step 2.

Terminate the Auto Cycle Test by removing the jumper from the “**TEST**” terminals, and cycling the unit power with the disconnect switch (off & on).

Note: If the jumper is inadvertently left across the “**TEST**” terminals, the UCP will automatically exit the test mode after it has completed the test steps, and ignore the jumper.

Method 2. Resistance Test.

This test is best suited to force the unit into a specific test step. A selection of resistors, or a decade resistor box is required. This takes the guess work out of what test step the unit is in.

Step 1.

Initiate the Resistance Test by installing the proper resistor across the “**TEST**” terminals on the unit’s Low Voltage Terminal Board (LTB), (See Test Mode Table page 13). The LED on the UCP will begin to blink, indicating the unit is in the test mode, and the system will operate in the desired mode.

Step 2.

Terminate the Resistance Test by removing the resistor from the “**TEST**” terminals, and cycling the unit power with the disconnect switch (off & on).

Note: If the unit is inadvertently left in the Resistance Test, with the resistor in place across the “**TEST**” terminals, the UCP will automatically exit the test mode after one hour, and ignore the resistor across the “**TEST**” terminals.

Resetting Cooling Failures And Ignition Lockouts

Cooling Failures, and Ignition Lockouts are reset in an identical manner. **Method 1:** Deals with resetting the unit from the space, for both Cooling Failures and Ignition Lockouts. **Method 2:** Deals with resetting the unit from the roof, for both cooling failures and ignition lockouts.

Method 1:

Resetting The Unit From The Space. To RESET the unit in the space, in the event of a Cooling Failure or Ignition Lockout, set the ZSM mode switch in the OFF position for approximately 30 seconds. After that time, set the mode switch in the position of desired unit operation (HEAT, COOL, or AUTO)

Note: Before resetting Cooling Failures and Ignition Lockouts by method #2 check the Failure Status Diagnostics by the methods previously explained in this document (See Table of Contents). If you disconnect power to the unit the diagnostics will be lost.

Method 2:

Resetting The Unit From The Roof. To RESET the unit from the roof, in the event a Cooling Failure or Ignition Lockout, cycle the unit power at the service disconnect (off & on).

Zone Sensor Module (ZSM) Service Indicator

The ZSM SERVICE LED is a generic indicator, that will signal the closing of a Normally Open switch at any time, providing the Indoor Motor (IDM) is operating. This indicator is usually used to indicate a clogged filter, or an air side fan failure.

The UCP will ignore the closing of this Normally Open switch for 2 (± 1) minutes. This helps prevent nuisance SERVICE LED indications. The exception is when the AFF (Active Fan Failure) is installed to the UEM board the LED will flash 40 secs after fan is turned on.

Clogged Filter Switch

This LED will remain lit the entire time that the Normally Open switch is closed. The LED will be turned off immediately after resetting the switch (to the Normally Open position), or any time that the IDM is turned off.

If the switch remains closed, and the IDM is turned on, the SERVICE LED will be turned on again after the 2 (± 1) minutes.

This LED being turned on, will have no other affect on unit operation. It is an indicator only.

Active Fan Failure Switch

This LED will remain flashing the entire time the switch is closed and until the unit is reset by means explained above. When the AFF switch is opened, indicating a fan failure, it will shut the unit operations down.

Zone Sensor Module (ZSM)

Test Procedures

Note: These procedures are not for programmable or digital models, and are conducted with the Zone Sensor Module electrically removed from the system.

Zone Sensor Module (ZSM) Terminal Identification

Terminal #	Terminal I.D.	Terminal #	Terminal I.D.
1	ZTEMP	6	LED COMMON
2	SIGNAL COMMON	7	HEAT LED
3	CSP	8	COOL LED
4	MODE	9	SYS ON LED
5	HSP	10	SERVICE LED

Test 1.

ZTEMP, or Zone Temperature Thermistor. This component is tested by measuring the resistance between terminals 1 and 2 on the Zone Sensor Module. Below are some typical indoor temperatures, and corresponding resistive values.

Zone or Set Point Temperature	Nominal ZTEMP Resistance	Nominal CSP or HSP Resistance
10°C - (50° F)	19.9 K-Ohms	889 Ohms
13°C - (55° F)	17.47 K-Ohms	812 Ohms
16°C - (60° F)	15.3 K-Ohms	695 Ohms
18°C - (65° F)	13.49 K-Ohms	597 Ohms
21°C - (70° F)	11.9 K-Ohms	500 Ohms
24°C - (75° F)	10.50 K-Ohms	403 Ohms
27°C - (80° F)	9.3 K-Ohms	305 Ohms
29°C - (85° F)	8.25 K-Ohms	208 Ohms
32°C - (90° F)	7.3 K-Ohms	110 Ohms

Test 2.

CSP and HSP, or Cooling Set Point and Heating Set Point. The resistance of these slide potentiometers are measured between the following ZSM terminals.

CSP = Terminals 2 and 3 /

Range = 100 to 900 Ohms approximate

HSP = Terminals 2 and 5 /

Range = 100 to 900 Ohms approximate

Note: See the chart above for approximate resistances at the given set points.

Test 3. MODE, or the combination of the System Selector switch, and the Fan Switch setting. The combined resistance of these 2 switches is measured between terminals 2 and 4 on the Zone Sensor Module. All of the possible switch combinations are listed below, with their corresponding resistance values.

System Switch	Fan Switch	Nominal Resistance
OFF	AUTO	2.3 K-Ohms
COOL	AUTO	4.9 K-Ohms
AUTO	AUTO	7.7 K-Ohms
OFF	ON	11.0 K-Ohms
COOL	ON	13.0 K-Ohms
AUTO	ON	16.0 K-Ohms
HEAT	AUTO	19.0 K-Ohms
HEAT	ON	28.0 K-Ohms
EM. HEAT	AUTO	35.0 K-Ohms
EM. HEAT	ON	43.0 K-Ohms

Test 4.

LED indicator test, (SYS ON, HEAT, COOL & SERVICE). Method 1. Testing the LED using a meter with diode test function. Test both forward and reverse bias. Forward bias should measure a voltage drop of 1.5 to 2.5 volts, depending on your meter. Reverse bias will show an Over Load, or open circuit indication if LED is functional. Method 2. Testing the LED with an analog Ohmmeter. Connect Ohmmeter across LED in one direction, then reverse the leads for the opposite direction. The LED should have at least 100 times more resistance in reverse direction, as compared with the forward direction. If high resistance in both directions, LED is open. If low in both directions, LED is shorted. Method 3. To test LED's with ZSM connected to unit, test voltages at LED terminals on ZSM. A measurement of 32 VDC, across an un-lit LED, means the LED has failed.

Note: Measurements should be made from LED common (ZSM terminal 6 to respective LED terminal). See Zone Sensor Module (ZSM) Terminal Identification on Preceding page.

Programmable & Digital Zone Sensor Module Test Procedure

Testing serial communication port voltage

Step 1:

Disconnect wires from LTB-11 and LTB-12. Measure voltage between LTB-11 and LTB-12, should be about 32 VDC.

Note: 24 VAC should be present between LTB-14 & LTB-11.

Step 2:

Re-connect wires to terminals LTB-11 and LTB-12. Measure voltage again between LTB-11 and LTB-12, voltage should flash high and low every 0.5 seconds. The voltage on the low end will measure about 19 VDC, while the voltage on the high end will measure from approximately 24 to 38 VDC.

Step 3:

Verify all modes of operation, by running the unit through all of the steps in the "Recommended Test Mode Procedure" on page 13.

Step 4:

After verifying proper unit operation, exit the test mode. Turn the fan on continuously at the ZSM, by pressing the button with the fan symbol. If the fan comes on and runs continuously, the ZSM is good. If you are not able to turn the fan on, the ZSM is defective.

Unitary control processor (UCP) Default Chart

If the UCP loses input from the Building Automation System, the UCP will control in the default mode after approximately 15 minutes. If the UCP loses input from the Zone Sensor Module's Heating and Cooling Setpoint (slide potentiometers), the UCP will control in the default mode instantaneously. The temperature sensing thermistor in the Zone Sensor Module is the ONLY component required for the Default Mode to operate.

Component or Function	Default Operation
Cooling Setpoint (CSP)	23°C (74°F)
Heating Setpoint (HSP)	22°C (71°F)
Economizer	Normal Operation
Economizer Minimum Position	Normal Operation
Mode	Normal operation, or auto if ZSM mode switch has failed
Fan	Normal operation, or continuous if fan mode switch on ZSM has failed
Night Setback Mode	Disabled - Used with Integrated Comfort™ System and Programmable ZSM's only
Supply Air Tempering	Disabled - Used with Integrated Comfort™ Systems only

Operating The Equipment Without A Zone Sensor Module

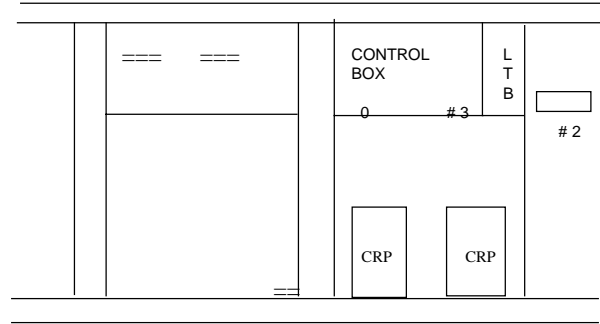

1. **Open** and **Lock** unit disconnect switch.
2. Locate hole in corner post, next to control box. Remove thermistor sensor (OAS), reaching around and behind corner post, slide sensor downward out of the rubber grommet.
3. Cut the two (2) splice caps in lower right hand corner of control box, and remove the sensor. Use two (2) wire nuts, to individually cap the wires in the control box.
4. Locate Low Voltage Terminal Board (LTB) on the right side of control box. Connect two (2) wires to terminals LTB - 1 and 2.
5. Take the sensor (OAS) and connect with wire nuts to two (2) field supplied wires that are connected to terminals 1 and 2 at the unit LTB.

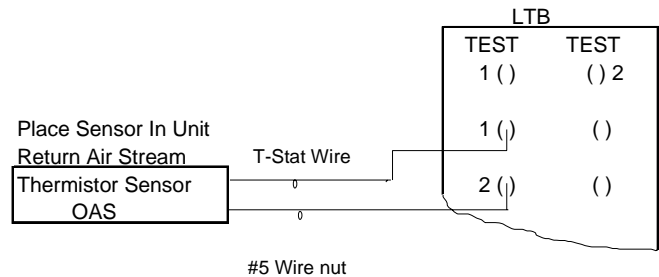

Note: This fix is for temporary operation only. Economizer, condenser fan cycling, and evaporator defrost functions are disabled. Evaporator will freeze during low ambient cooling.

Unitary Economizer Module (UEM)

Test Procedures

This series of tests will allow you to diagnose, and determine where, and if a problem exists in the system economizer operation. Test 1 determines if the problem is in the UCP, or if it is in the UEM or ECA. Test 2 will determine if the problem is in the UEM or the ECA. Test 3 is for the UEM's minimum position potentiometer. Test 4 tests sensor and exhaust fan outputs. Test 5 shows how to test the sensors. Conduct the tests in numerical order until problem is found.

Test 1: Verifying **UCP** communication with **UEM**.

Step 1.

Using the Recommended Test Mode Procedure on page 13. Step the unit into the economizer mode (STEP 2), and verify that the ECA drives fully open (approximately 90 seconds). The LED on the UEM glows continuously when the ECA drives.

Step 2.

If the ECA is not driving the dampers in Step 1, measure the DC voltage output from the UCP. This is measured between UEM connector P11-11 which is connected to J1 on the UEM, and P15-5 which is connected to J5 on the UEM. The voltage measured while the ECA is driving open should be approximately 1.7 VDC. When the 90 seconds have elapsed, and the dampers should be fully open, the voltage will change to approximately 5 VDC.

Step 3.

Using the Recommended Test Mode Procedure on page 13. Step the unit into the Cool 1 mode (STEP 3), the ECA should drive fully closed (approximately 90 seconds), and then open to the preset minimum position. The LED on the UEM glows continuously when the ECA drives.

Step 4.

If the ECA is not driving the dampers in Step 3, measure the DC voltage output from the UCP. This is measured between UEM connector P11-10 which is connected to J1 on the UEM, and P15-5 which is connected to J5 on the UEM. The voltage measured while the ECA is driving closed should be approximately 1.7 VDC. When the 90 seconds have elapsed, and the dampers should be fully closed, the voltage will change to approximately 5 VDC.

If the voltages above are present, the UCP is operating properly. If the ECA will not drive, the problem is in the UEM or ECA, continue to Test 2. If voltages are not present a wire, terminal, or UCP failure has occurred.

Test 2: Verifying that the ECA is functional.

Step 1.

With power applied to the system, in any mode, verify presence of 24 VAC between ECA terminals TR and TR1. If 24 VAC is not present, a wiring or terminal problem is present.

Step 2.

Jumper terminal TR1 to terminal CCW, ECA should begin to drive open. Should be at fully open position after approximately 90 seconds. Remove jumper from CCW terminal.

Step 3.

Jumper terminal TR1 to terminal CW, ECA should begin to drive closed. Should be at fully closed position after approximately 90 seconds. Remove jumper from both terminals.

If after completing Test 1, and the ECA functions in Test 2, the UEM has failed. If 24 VAC is present in Step 1, and ECA did not drive as specified in Steps 2 and 3, ECA is defective. Replace ECA.

Test 3: Testing the UEM minimum position potentiometer.

Step 1.

With power applied to the system, in any mode, verify the presence of 5 VDC at the following two points. Voltage is measured at connector P11, which is connected to J1 on the UEM. Measure between P11-1 and P11-3, and P11-3 and P11-9. If 5 (± 0.25) VDC is not present at these two points, a wire, terminal, or UCP failure has occurred.

Step 2.

After verifying the voltage presence in Step 1, turn the minimum position potentiometer fully counter-clockwise. Measure the DC voltage between UEM terminals J11(+) and J12(-). Should be approximately 0.47 VDC.

Step 3.

Turn the minimum position potentiometer one half turn clockwise, so that the screw driver slot is straight up and down. Measured voltage should be approximately 1.18 VDC.

Step 4.

Turn the minimum position potentiometer fully clockwise. Measured voltage should be approximately 1.70 VDC.

If voltages measured are consistent with Steps 1, 2, 3, and 4 above, UCP, UEM potentiometer and circuitry are good. Continue to Test 4 if necessary.

Test 4: Testing sensor inputs and exhaust fan output.

Step 1.

With power applied to the system, turn the ZSM mode switch OFF, and the ZSM fan switch ON. Verify the DC voltages in the steps below.

Step 2.

Testing Supply Air Sensor input. Disconnect connector P12 from J2 on UEM, marked SA on the side of the board. Measure voltage between pins J2-1 and J2-2. Voltage should measure 5 (± 0.25) VDC.

Step 3.

Testing Return Air Sensor input. Disconnect connector P13 from J3 on UEM (if installed), marked RA on the side of the board. Measure voltage between pins J3-1 and J3-2. Voltage should measure 5 (± 0.25) VDC.

Step 4.

Testing Return Humidity Sensor input. Disconnect wires (if installed) from terminals J7 (-) and J8 (+) on UEM, marked RH on the side of the board. Measure voltage between terminals J7 (-) and J8 (+). Voltage should measure approximately 20 VDC.

Step 5.

Testing Outdoor Humidity Sensor input. Disconnect wires (if installed) from terminals J9 (-) and J10 (+) on UEM, marked OH on the side of the board. Measure voltage between terminals J9 (-) and J10 (+). Voltage should measure approximately 20 VDC.

Step 6.

Testing Exhaust Fan Contactor output. Disconnect connector (if installed) from J6 on UEM, marked XFC on the side of the board. Turn minimum position potentiometer fully counter-clockwise. Measure DC voltage between J6-1 and J6-2, should be ZERO. Turn minimum position potentiometer fully clockwise, after approximately 25 seconds, voltage should measure approximately 30 VDC.

Step 7.

Testing Active Fan Failure input. Disconnect P15 from J5 on the UEM and measure voltage across J5-3 and J5-4 voltage should measure 5 (± 0.25) VDC.

If after completing tests 1 through 4, if any of the voltages specified in Test 4 were not present, the UEM has failed.

Note: The Outdoor Air Sensor (OAS) is also used in economizer operation, however it is connected to the UCP. Disconnect OAS at the splice caps in the lower right hand corner of the control box, test voltage at wires going to UCP. Should be 5 (± 0.25) VDC. Using Thermistor Resistance / Temperature Chart on page 11, test the integrity of the OAS.

Test 5: Testing the UEM's sensors.

Step 1.

Testing the Supply Air Sensor (SAS). Disconnect connector P12 from J2 on UEM, marked SA on the side of the board. Using the Thermistor Resistance / Temperature Chart on page 11, measure the resistance of the sensor between the connector terminals P12-1 and P12-2. Replace if out of range.

Step 2.

Testing the Return Air Sensor (RAS). Disconnect connector P13 from J3 on UEM, marked RA on the side of the board. Using the Thermistor Resistance / Temperature Chart on page 11, measure the resistance of the sensor between the connector terminals P13-1 and P13-2. Replace if out of range.

Step 3.

Testing Return Humidity Sensor (RHS). Leave the sensor connected to the UEM, and measure the operating current. The normal range for operating current is 4 to 20 mA (milliamps). Replace if out of range.

Note: The RHS is polarity sensitive, verify polarity is correct before condemning. Incorrect wiring will not damage any of the controls, but RHS will not work if wired incorrectly.

Step 4.

Testing Outdoor Humidity Sensor (OHS). Leave the sensor connected to the UEM, and measure the operating current. The normal range for operating current is 4 to 20 mA (milliamps). Replace if out of range.

Note: The OHS is polarity sensitive, verify polarity is correct before condemning. Incorrect wiring will not damage any of the controls, but OHS will not work if wired incorrectly.

Defrost Module (DFM)

100 - 200 Units Only Test and Operation

The defrost function is a Time and Temperature operation, similar to many solid state defrost boards used today. The only difference is that the timing function is provided by the UCP, and the coil temperature information is provided by the Defrost Module. Four defrost time intervals can be selected by changing the switch positions of switch 1, and switch 2 located on the Defrost Module.

Three conditions must be met to initiate defrost.

1. Mechanical heating must be operating.
2. Defrost termination switch must be in the closed position.
3. Accumulated compressor run time exceeds selected interval.

When defrost is initiated, the Switch Over Valves (SOV's) are energized, the compressors continue to run, and the outdoor fan motor(s) are turned off. Resistance heat, if installed, is turned on to maintain zone temperature.

Once a defrost cycle has been initiated, the cycle will continue until it has completed. Even if the Zone Sensor Module has stopped calling for heat.

Defrost is terminated when one of three events occur.

1. Defrost termination switch opens.
2. Defrost cycle has been operating for 10 minutes.
3. High pressure control opens in either compressor circuit.

When a defrost cycle is terminated, the condenser fan(s) are turned on approximately 5 seconds before de-energizing the Switch Over Valves (SOV's). This is the "**Soft Start**" feature.

The chart below will allow you to bench test the Defrost Module when it is electrically disconnected from the unit.

Defrost Time	Switch 1	Switch2	Resistance between pins J2-3 & J2-1 on (DFM)
70 Min.	OFF	OFF	Approximately 50.0 K
90 Min.	ON	OFF	Approximately 34.0 K
60 Min.	OFF	ON	Approximately 23.0 K
45 Min.	ON	ON	Approximately 7.0 K

If the UCP sees an out of range temperature / resistance from the Defrost Module due to an open or shorted circuit, a 10 minute defrost cycle will be initiated by the UCP after each 70 minutes of accumulated compressor run time.

A failure of this type will cause the HEAT and COOL LED's to blink at the Zone Sensor Module (if applicable). This will also indicate a simultaneous HEAT and COOL failure at the low voltage terminal board (LTB).

As long as the on board relay on the Defrost Module, and it's controlling circuitry remains intact to energize the Switch Over Valves (SOV's), defrost will still occur.

Testing The Defrost Module (DFM) In The Unit

This is the most accurate Defrost Module test, as it allows the proper testing of the Defrost Termination switch (DT) circuit. The DT circuit parallels the Switch 1 (SW1), and Switch 2 (SW2) (defrost interval) circuits when the DT closes, indicating to the UCP that the temperature is sufficient to warrant coil defrost. These tests can be conducted in any mode, as long as the UCP is powered up. Test 1 will be conducted simulating an open DT switch, and the test 2 will be conducted simulating a closed DT switch. Test 3 deals with testing the (SOV's) relay circuit.

Test 1: Remove the RED wire from terminal number J6 on the DFM, to simulate an open DDT condition. Slide connector P22 about half way off of the J2 pins on the DFM. Measure the DC voltage between pin J2-3 and LTB-20. With the switches (SW1) and (SW2) set in the positions below, the voltage should read as follows:

SW1	SW2	DT	Expected DC Volts
OFF	OFF	OPEN	0.56 ± 10%
ON	OFF	OPEN	0.54 ± 10%
OFF	ON	OPEN	0.52 ± 10%
ON	ON	OPEN	0.41 ± 10%

Test 2: Re-connect the RED wire to terminal J6 on DFM. Install a jumper from terminal J6 to LTB-14 to simulate a closed DT. Leave the P22 connector slid back, and measure DC voltage between pin J2-3 and LTB-20. With the switches (SW1 and SW2) set in the positions below, the voltage should read as follows.

SW1	SW2	DT	Expected DC Volts
OFF	OFF	CLOSED	3.3 ± 10%
ON	OFF	CLOSED	2.9 ± 10%
OFF	ON	CLOSED	2.4 ± 10%
ON	ON	CLOSED	1.0 ± 10%

Important Note: If any voltage measured is out of range for a particular switch setting combination, an alternative switch combination that is within range, may be used instead of replacing the DFM.

Test 3: This test will allow you to check and verify the SOV's relay circuit, from the SOV's, to the UCP.

Step 1.

Place the unit in cooling, or Defrost mode so that the SOV's should be energized. Test for 24 VAC, with wires in place, between DFM terminals J3 and J4. If 24 VAC is not present, contacts should be closed, and SOV's should be energized. If 24 VAC is present, K1 contacts are not closed, and SOV's will not be energized.

Step 2.

Test for K1 relay Coil Voltage, remove P21 connector from J1 pins on DFM. Test the P21 terminals for nominal 28 VDC. If voltage is present, and K1 contacts are not closed, DFM is defective.

Step 3.

If 28 VDC is not present, open unit disconnect switch. Locate P1 connector, which is connected to J1 on the UCP. Locate terminals P1-14, and insert the end of a small paper clip into the connector next to wire # 83A BLACK.

Step 4.

Close the unit disconnect switch, and place the unit in Cooling, or Defrost mode so that the SOV's should be energized. Connect negative meter lead to LTB-16 screw terminal, and measure voltage between LTB-16 and paper clip. If 28 VDC is present, a wiring or terminal problem exists, If 28 VDC is not present, the UCP is defective.

Conventional Thermostat Interface (CTI) Test Procedures

This series of tests will allow you to test the CTI, and verify the output to the UCP. **Test 1** will verify the Mode output. **Test 2** will verify the Cooling Setpoint output. **Test 3** will verify the Heating Setpoint output. **Test 4** will verify the Zone Temperature output. Conduct the tests in numerical order until the problem is found.

Note: Disconnect system power, while instrumenting the unit, at the service disconnect. Re-apply power to the unit for testing.

Test 1: Testing the Mode output.

Step 1.

After checking the Room Thermostat, disconnect the unit power at the service disconnect, and remove the thermostat wires at the unit LTB.

Step 2.

Locate connector P35, connected to J7 on the UCP. Install meter leads between connector terminals P35-2 and P35-10, re-apply power, then measure the DC voltage. The DC voltage measured should flash approximately every 0.5 second. The voltage level should measure less than 0.8 VDC at the low end of the cycle, and greater than 2.5 VDC at the high end of the cycle.

Test 2: Testing the Cooling Setpoint output.

Step 1.

Disconnect the unit power at the service disconnect.

Step 2.

Locate connector P35, connected to J7 on the UCP. Re-instrument the unit by installing meter leads between connector terminals P35-2 and P35-8, re- apply power, then measure the DC voltage. Jumper the following terminals on the LTB, the voltage measured should be as follows:

Terminals Jumpered	Expected DC Volts	DC Volts Measured
NONE	5.0 (± 5 %)	
LTB-14 to LTB-1	3.7 (± 5 %)	
LTB-14 to LTB-4	3.1 (± 5 %)	
LTB-14 to LTB-1 & 4	2.6 (± 5 %)	

Test 3: Testing the Heating Setpoint output.

Step 1.

Disconnect the unit power at the service disconnect.

Step 2.

Locate connector P35, connected to J7 on the UCP. Re-instrument the unit by installing meter leads between connector terminals P35-2 and P35-9, re-apply power, then measure the DC voltage. Jumper the following terminals on the LTB, the voltage measured should be as follows:

Terminals Jumpered	Expected DC Volts	DC Volts Measured
NONE	5.00 (± 5 %)	
LTB-14 to LTB-5	2.80 (± 5 %)	
LTB-14 to LTB-3	3.70 (± 5 %)	
LTB-14 to LTB-9	3.10 (± 5 %)	
LTB-14 to LTB-5,3 & 9	1.80 (± 5 %)	

Test 4: Testing the Zone Temperature output.

Step 1.

Disconnect the unit power at the service disconnect.

Step 2.

Locate connector P35, connected to J7 on the UCP. Re-instrument the unit by installing meter leads between connector terminals P35-2 and P35-11, re-apply power, then measure the DC voltage. Jumper the following terminals on the LTB, the voltage measured should be as follows:

Terminals Jumpered	Expected DC Volts	DC Volts Measured
NONE	5.00 (± 5 %)	
LTB-14 to LTB-7	3.70 (± 5 %)	
LTB-14 to LTB-8	3.10 (± 5 %)	
LTB-14 to LTB-7 & 8	2.60 (± 5 %)	

System Troubleshooting Chart (TK, WK, YK)

Always operate the unit in the proper mode when diagnosing.

SYMPTOM	PROBABLE CAUSE	RECOMMENDED ACTION
A. Unit will not operate. No Heat, no Fan operation.	<ol style="list-style-type: none"> 1. No power to unit. 2. No power to UCP. 3. UCP F1 fuse is defective. 4. Zone Sensor Module (ZSM) is defective. 5. UCP is defective. 6. AFF Switch has tripped 	<ol style="list-style-type: none"> 1. Check line voltage at service disconnect. 2. Check for 24 VAC from Cool, bottom of F1 fuse to system ground. 3. Check for 24 VAC from top of F1 fuse to system ground. If 24VAC is not present, replace F1 fuse. 4. See Zone Sensor Module (ZSM) Test Procedures on page 16. 5. If 24 VAC is present from top of F1 fuse to ground, LED on UCP should be on. If LED is not on, replace UCP. 6. Check IDM and belts, replace as necessary.
B. Unit will not Heat or Cool, but Fan switch operates.	<ol style="list-style-type: none"> 1. Zone Sensor Module (ZSM) is defective. 2. Problem in (ZSM) wiring. 3. UCP is defective. 	<ol style="list-style-type: none"> 1. See Zone Sensor Module (ZSM) Test Procedures on page 16. 2. Verify all terminal to terminal connections from LTB to ZSM. Disconnect ZSM wiring from unit LTB, and test wires using Zone Sensor Module (ZSM) Test Procedures on page 16. This will help locate any wiring problems. 3. Disconnect connector P7 from UCP, and test at connector using Zone Module (ZSM) Test Procedures on page 16. If within range replace UCP.
C. Unit heats and cools, will not control to set point.	<ol style="list-style-type: none"> 1. ZSM is defective. Cool Failure Possible. 2. Thermometer on ZSM out of calibration. 	<ol style="list-style-type: none"> 1. See Zone Sensor Module (ZSM) Test Procedures on page 16. See Unitary Control Processor (UCP) Default Chart page 17. 2. Check and re-calibrate ZSM's thermometer.
D. CPR1 will not operate, ODM1 operates.	<ol style="list-style-type: none"> 1. Compressor failure. 2. Wiring, terminal, or mechanical CC1 contactor failure. 3. LPC1 has tripped 	<ol style="list-style-type: none"> 1. Test compressor, mechanically and electrically. Replace if necessary. 2. Check wires, terminals, and CC1. Repair or replace if necessary. 3. Leak check, repair, evacuate and recharge as necessary. Check LPC1 operation.
E. CPR1 operates, ODM1 will not operate.	<ol style="list-style-type: none"> 1. ODM1 has failed. 2. CF1 capacitor has failed. 3. Wiring, terminal, or mechanical CC1 contactor failure. 4. ODF2 relay has failed. (WK's Only) 5. UCP is defective. (WK's Only) 	<ol style="list-style-type: none"> 1. Check ODM1, replace if necessary. 2. Check CF1 capacitor, replace if necessary. 3. Check wires, terminals, and CC1. Repair or replace if necessary. 4. Check ODF2, Note: ODF2 has a 24 VDC coil. Test for proper voltage, and contact closure. If 24 VDC is present and contacts not closed, replace ODF2. 5. Locate P1 connector at J1 on UCP. Test output between terminals P1-11 wire 89A YELLOW & P1-12 wire 42A BLUE. UCP bad if 24 VDC not present.
F. CPR1 and ODM1 will not operate.	<ol style="list-style-type: none"> 1. No power to CC1 coil. Cool Failure Possible. 2. CC1 coil defective. Cool Failure Indicated. 3. CC1 contacts defective. 4. UCP is defective. 5. LPC1 has tripped (single compressor units) 	<ol style="list-style-type: none"> 1. Check wiring, terminals and applicable controls (HPC1, LPC1) 2. Verify integrity of CC1 coil windings. If open or shorted replace CC1. 3. 24 VAC present at CC1 coil, verify contact closure and integrity. 4. 24 VAC is not present at CC1 coil. Reset the Cool Failure by cycling the service disconnect. Run unit in proper mode calling for compressor operation. Test devices in #1 & #2 above, if no controls have opened, and CC1 will not close, replace UCP. 5. Leak check, repair, evacuate, and recharge as necessary. Check LPC1 operation.

SYMPTOM	PROBABLE CAUSE	RECOMMENDED ACTION
G. ODM2 will not operate.	<ol style="list-style-type: none"> 1. OAS sensing 16°C (60°F) ambient or lower. 2. CF2 capacitor has failed. 3. Wiring, terminal, or mechanical CC2 contactor failure. 4. ODM2 has failed. 5. UCP K4 relay, or ODF1 (Not Used On All Units) relay, has failed. 6. UCP is defective. 	<ol style="list-style-type: none"> 1. Test OAS at connector P1, disconnect P1 from J1 on UCP. Test between P1-15 and P1-16, see Thermistor Resistance / Temperature chart on page 11. Replace if necessary. 2. Check CF2 capacitor, replace if necessary. 3. Check wires, terminals, and CC2. Repair or replace if necessary. 4. Check ODM2, replace if necessary. 5. Test for line voltage between ODF1 (If Used) contacts. If line voltage is present, test for 24 VAC at ODF1 coil. If 24 VAC is present, ODF1 has failed. If 24 VAC is not present, and on units without ODF1, test K4 relay on UCP. Test for line, or control voltage (which ever is applicable) between K4 Com. & N.O. terminals. If voltage is not present, contacts are closed. See probable cause #3. 6. If voltage is present, contacts are open. Test for relay coil voltage at K4. Test at solder joints CR11 above K4 on UCP. Nominal voltage at coil is 28 VDC, if voltage is present, UCP has failed. Note: If voltage is not present, verify that ODM2 should be operating in the mode the unit is in.
H. CPR2 will not operate.	<ol style="list-style-type: none"> 1. No power to CC2 coil. Cool Failure Possible. 2. CC2 coil defective. Cool Failure Indicated. 3. CC2 contacts defective. 4. UCP is defective. 5. LPC2 has tripped. 	<ol style="list-style-type: none"> 1. Check wiring, terminals and applicable controls (HPC2, LPC2) 2. Verify integrity of CC2 coil windings. If open or shorted replace CC2. 3. If 24 VAC is present at CC2 coil, contacts are closed, line voltage is present, load voltage is absent. Replace CC2. 4. 24 VAC is not present at CC2 coil. Reset the Cool Failure by cycling the service disconnect. Step the unit into step 4, Mode Cool 2, to insure CPR2 Compressor operation. Test devices in #1 & #2 above, if no controls have opened, and CC2 will not close, replace UCP. 5. Leak check, repair, evacuate, and recharge as necessary. Check LPC2 operation.
I. Indoor motor .IDM will not operate	<ol style="list-style-type: none"> 1. IDM has failed. 2. Wiring, terminal, or contactor failure. 3. ZSM is defective. 4. UCP is defective. 5. AFF has opened 	<ol style="list-style-type: none"> 1. Check IDM, replace if necessary. 2. Check wiring, terminals and F contactor. Repair or replace wiring, terminals, or fan contactor F. 3. Place unit in test mode page 13. If fan operates in test mode, test ZSM using test procedures beginning on page 13. 4. If integrity of above has been verified, test UCP fan output. Locate P2 connector, which is connected to J2 on UCP. Find wire 64A BLACK and measure voltage to ground. If 24 VAC is not present on a call for fan, replace UCP. 5. Check IDM and belts, repair or replace if necessary.
J. No Heat (YK's only) IP warms up, GV is energized, CFM will not run.	<ol style="list-style-type: none"> 1. CFM has failed. 2. CFM capacitor has failed. 3. Wiring, or terminal failure. 4. Heat relay H has failed. 5. TNS2 has failed. 	<ol style="list-style-type: none"> 1. Check CFM, replace if necessary. 2. Disconnect BROWN wires from capacitor, test, and replace if necessary. 3. Check wiring, and terminals. Repair, or replace if necessary. 4. Check for line voltage between terminals 1 & 3 on heat relay. If line voltage is present, contacts are open. Check for 24 VAC at H coil, replace H if 24 VAC is present. 5. Test for 230 VAC at TNS2 secondary, between Y1 and Y2. If 230 VAC is not present, replace TNS2.
K. No Heat (YK's only) CFM runs, GV energizes, IP does not warm up.	<ol style="list-style-type: none"> 1. TNS2 has failed. 2. Wiring or terminal failure. 3. IGN has failed. 4. IP has failed. 	<ol style="list-style-type: none"> 1. Test for 115 VAC at TNS2 secondary, between X1 and X2. If 115 VAC is not present, replace TNS2. 2. Check wiring, and terminals. Repair, or replace if necessary. 3. Verify presence of 115 VAC at IGN L1 and L2. Test for 115 VAC in gas section, at PPM4-1 and PPM4-2 (RED WIRES). If 115 VAC is present for IP warm up, IGN is OK. If 115 VAC is not present, replace IGN. 4. With 115 VAC applied to IP, warm up should take place. Cold resistance of IP should be a minimum of 50 Ohms. Nominal current should be 2.5 to 3.0 Amps.

SYMPTOM	PROBABLE CAUSE	RECOMMENDED ACTION
<p>L. No Heat (YK's only) M³/L (CFM) runs, IP warms up, GV does not energize.</p>	<ol style="list-style-type: none"> 1. Wiring or terminal failure. 2. IGN has failed 3. GV has failed. 	<ol style="list-style-type: none"> 1. Verify presence of 24 VAC between IGN PWR terminal to ground, if not present check wiring and terminals. Repair or replace if necessary. 2. Verify presence of 24 VAC between IGN VALVE terminal to ground, if not present replace IGN. 3. Measure voltage between GV terminal with BLUE wire, and GV terminal with BROWN wire. If 24 VAC is present, and GV will not open, replace GV.
<p>M. Low Heat Capacity. Intermittant Heat. (YK's only) CFM will not change speeds, runs in LO or HI speed only, may not operate at all in one speed or the other.</p>	<ol style="list-style-type: none"> 1. CFM has failed. 2. UCP is defective. 	<ol style="list-style-type: none"> 1. Check CFM, test LO and HI speed windings. 2. Test UCP K5 relay. Test for K5 coil voltage at solder joints CR16 above K5 on UCP. Nominal voltage at coil is 28 VDC. If 28 VDC is present, COM. & N.O. contacts should be closed, energizing CFM HI speed windings. If 28 VDC is not present, LO speed should be energized through K5 COM. & N.C. contacts. If voltage contradicts operation, UCP has failed.
<p>N. No Heat (YK's only) FAN switch on ZSM in AUTO, IDM runs continuously.</p>	<ol style="list-style-type: none"> 1. TCO1, or TCO2 has opened. Heat Failure Indicated. 	<ol style="list-style-type: none"> 1. See Failure Status Diagnostic Sheet on page 12. Test for heating failure, make necessary repairs or adjustments to unit.
<p>O. No Mechanical Heat (WK's only)</p>	<ol style="list-style-type: none"> 1. CPR1 and CPR2 will not run. 2. Low on refrigerant charge. 3. LPC1 and/or LPC2 tripped. 	<ol style="list-style-type: none"> 1. See sections E and G, on pages 14, and 15. 2. Leak check, repair, evacuate, and recharge as necessary. 3. Same as above and check LPC1, LPC2 operation.
<p>P. No Heat (TK's and WK's only) Auxiliary electric heat will not operate.</p>	<ol style="list-style-type: none"> 1. Heater contactor(s) have failed. 2. Element Temperature Limit(s) is open. 3. Wiring or terminal failure. 4. Heater Element(s) has failed. 5. UCP is defective. 	<ol style="list-style-type: none"> 1. Test for 24 VAC at AH, BH,CH, and DH contactor coils. If 24 VAC is present on a call for heat, and contacts do not close, contactor has failed. 2. Test for line voltage between terminals on element temperature limits located in heat section. If line voltage is present, limit is open. Repair unit, or replace limit as needed. 3. Check for wiring, or terminal failure in control and power circuit. Repair or replace if necessary. 4. Test element integrity, circuit. Repair or replace if necessary.replace open elements. 5. Test UCP heat outputs. First stage, locate P1 connector, connected to J1 on the UCP. Find 47C BROWN wire at terminal P1-22, measure voltage J1 on the UCP. Find 47C BROWN wire at terminal P1-22, measure to ground. If 24 VAC is present, see #3 above. UCP has failed if 24 VAC is not present. Second stage, test UCP K5 relay. Measure from COM. contact to ground, should be 24 VAC, if not see #3 above. If present, measure from N.O. to ground. If not present UCP has failed.

SYMPTOM	PROBABLE CAUSE	RECOMMENDED ACTION
Q. Evaporator coil freezes up during low ambient operation.	<ol style="list-style-type: none"> 1. System low on refrigerant charge. 2. System low on air flow. 3. Outdoor Air Sensor (OAS) has failed. 	<ol style="list-style-type: none"> 1. Leak check, repair, evacuate, and recharge system as necessary. 2. Check return air for obstruction, or dirty filters. Check fans, motors, and belts. 3. Test OAS at connector P1, disconnect P1 from J1 on UCP. Test between P1-15 and P1-16, see Thermistor Resistance / Temperature chart on page 11. Replace if necessary.
R. Economizer will not operate.	<ol style="list-style-type: none"> 1. Economizer connector not plugged into unit wiring harness. 2. Economizer Actuator (ECA) has failed. 3. Unitary Economizer Module (UEM) has failed. 4. Wiring, or terminal failure. 5. UCP is defective. 	<ol style="list-style-type: none"> 1. Check connector, and connect if necessary. 2. Verify that 24 VAC is present between ECA terminals TR and TR1. Jumper TR1 to CCW, ECA should drive open. Jumper TR1 to CW, ECA should drive closed. If ECA does not drive as specified, replace ECA. 3. See UEM Test Procedures on pages 17, 18, and 19. 4. Check wiring, and terminals. Repair, or replace if necessary. 5. See UEM Test Procedures on pages 17, 18, and 19.
S. Minimum position is at zero, cannot be adjusted. Economizer still modulates.	<ol style="list-style-type: none"> 1. Minimum position potentiometer has failed. 	<ol style="list-style-type: none"> 1. Test at UEM terminals J11 and J12. With unit power off, rotate on board pot. Resistance should be 50 to 200 Ohms. With power on, DC voltage should measure 0.40 to 1.80 VDC. Also see UEM Test Procedures on pages 17, 18, and 19.
T. Economizer goes to minimum position, will not modulate.	<ol style="list-style-type: none"> 1. OAS has failed. 2. SAS has failed. 	<ol style="list-style-type: none"> 1. Test OAS at connector P1, disconnect P1 from J1 on UCP. Test between P1-15 and P1-16, see Thermistor Resistance /Temperature Chart on page 11. Replace if necessary. 2. Test SAS at connector P12, disconnect P12 from J2 on UEM. (SA) is marked on the side of the board. Test between P12-1 and P12-2, see Thermistor Resistance /Temperature Chart on page 11. Replace if necessary.
U. Economizer modulates, but system does not seem to operate as efficiently as in the past.	<ol style="list-style-type: none"> 1. Comparative enthalpy set up, RAS or RHS failed. System is operating using Reference enthalpy. 2. Reference enthalpy set up, OHS has failed. System is operating using dry bulb control. 3. Comparative enthalpy set up, OHS has failed. System is operating using dry bulb control. 	<ol style="list-style-type: none"> 1. Test RAS at connector P13, disconnect P13 from J3 on UEM. (RA) is marked on the side of the board. Test between P13-1 and P13-2, see Thermistor Resistance /Temperature Chart on page 11. Replace if necessary. Test RHS Note: humidity sensors are polarity sensitive, and will not operate if connected backwards. Measure operating current at UEM terminals J7 (-), and J8 (+). Normal operating current is 4 to 20 milliamps mA. 2. OHS is tested identical to RHS above. Measure operating current at UEM terminals J9 (-), and J10 (+). 3. See #2 above.
V. Power Exhaust will not operate.	<ol style="list-style-type: none"> 1. Exhaust motor has failed. 2. XFC failed. 3. UEM failed. 	<ol style="list-style-type: none"> 1. Test exhaust motor, and replace if necessary. 2. Test XFC contactor. 3. Test Procedure pages 17, 18, and 19.

SYMPTOM	PROBABLE CAUSE	RECOMMENDED ACTION
<p>W. (Demand Defrost) System Defrosts on Time Default</p>	<ol style="list-style-type: none"> 1. Coil Temperature Sensor Failure 2. OAS Failure 3. Low Refrigerant Charge 4. High Wind 5. Severe Ice Blockage 6. Outdoor Fan continuing to Operate During Defrost 7. Outdoor Fan Failure 8. Improperly Installed CTS or OAS 	<ol style="list-style-type: none"> 1. Test CTS at connectors P2, disconnect P2 from J2 on the UCP. Test between P2-21 and P2-15 and also between P2-21 and P2-17. See thermistor resistance / temperature chart. Replace if necessary. If economizer is installed, test CTS at connector P14. Disconnect P14 from J4 on UEM. Test between P14-2 and P14-3. See thermistor resistance / temperature chart. Replace if necessary. 2. Test OAS at connector P1, disconnect P1 from J1 on UCP. Test between P1-15 and P1-16, see thermistor resistance / temperature chart on page 11. Replace if necessary. 3. See Service Facts, test and verify for proper operating pressure. 4. Nuisance failure 5. Snow or ice build up due to location or installation. 6. Check Outdoor Fan relay, Note: ODF has a 24 VDC coil. If coil voltage is present during defrost UCP has failed. If no coil voltage is present during defrost and contacts are closed, replace ODF. 7. Check Outdoor Motor and replace if necessary. Check CF1 capacitor and replace if necessary. Check ODF and replace if necessary. 8. Check to ensure OAS is properly located in corner post grommet in outdoor air stream. Check to ensure CTS is properly attached to outdoor coil.

System Adaptive Operation Chart

The UCP allows operation to continue in cases where certain components have failed, providing comfort when needed most.

Note: Consult system wiring for components used in each unit.

COMPONENT	FAILURE RESPONSE	NORMAL RANGE	DIAGNOSTIC
(OAS) Outdoor Air Sensor	1.Economizer in minimum position. Will not modulate.	-48° to 79°C (-55° TO 175° F) 680K to 1.2K Thermistor Chart p. 11.	*NONE* Test at UCP connector P1, between P1-15 & P1-16.
	2.ODM2 will not cycle off at 60° F. runs continuously.	-48° to 79°C (-55° to 175° F) 680K to 1.2K Thermistor Chart p. 11.	*NONE* Test at UCP connector P1, between P1-15 & P1-16.
	3.Evaporator coil freezes in low ambient operation.	-48° to 79°C (-55° to 175° F) 680K to 1.2K Thermistor Chart p. 11.	*NONE* Test at UCP connector P1, between P1-15 & P1-16.
(RAS) Return Air Sensor Comparative Enthalpy only	1.Economizer operates using Reference Enthalpy.	-18° (-98°C) (0° to 209° F) 90K to 7.1K Thermistor Chart p. 11.	*NONE* Test at UEM connector P13, between P13-1 & P13-2.
(SAS) Supply Air Sensor	1.Economizer in minimum position, will not modulate.	-18° (-98°C) (0° to 209° F) 90K to 7.1K Thermistor Chart p. 11.	*NONE* Test at UEM connector P12, between P12-1 & P12-2.
(OHS) Outdoor Humidity Sensor	1.Uses Dry Bulb operation, and economizes if below 60° F DB.	4 to 20 mA 90 to 10% RH Honeywell C7600A.	*NONE* Test at UEM J9(-) and J10(+) measure current level.
(RHS) Return Humidity Sensor	1.Economizer operates using Reference Enthalpy.	4 to 20 mA 90 to 10% RH Honeywell C7600A.	*NONE* Test at UEM J7(-) and J8(+) measure current level.
Minimum Position Potentiometer	1.Economizer modulates, but minimum position stays at zero.	Range on UEM onboard Pot. 50 to 200 Ohms.	*NONE* Test at UEM terminals J11 & J12, 50 to 200 Ohms.
(CSP) Cooling Set Point, ZSM slide potentiometer.	1.Uses HSP and CSP=HSP -2°C (4° F) or uses UCP Default Mode.	100 to 900 Ohms See ZSM Test Procedures.	Cool Failure approx.at LTB-8 to LTB-6 COOL LED blinks at ZSM.
(HSP) Heating Set Point, ZSM slide potentiometer.	1.Uses CSP and HSP=CSP -2°C (4° F)	100 to 900 Ohms approx. See ZSM Test Procedures.	*NONE* Test at terminals 2 & 5 on ZSM.
HSP and CSP are both lost.	1.Cannot control at ZSM, unit using UCP Default Mode.	100 to 900 Ohms approx. See ZSM Test Procedures.	Cool Failure at LTB-8 to LTB-6 COOL LED blinks at ZSM.

COMPONENT	FAILURE RESPONSE	NORMAL RANGE	DIAGNOSTIC
(ZTEMP) Zone Temperature Sensor	1.No Heating, Cooling, ZSM FAN switch operates IDM.	No- 4° to 60°C (40° TO 150°) 346K to 2.1K Thermistor Chart p. 11.	Cool Failure at LTB-8 to LTB-6 COOL LED blinks at ZSM.
(TCO1) High Limit Cutout	Heat goes off, IDM runs continuously.	Normally Closed Temp. varies by unit.	Heat Failure at LTB-7 to LTB-6 HEAT LED blinks at ZSM.
(TCO2) Fan Failure Limit	Heat goes off, IDM runs continuously.	Normally Closed Open 57°C (135°F) Reset 41°C (105°F.	Heat Failure at LTB-7 to LTB-6 HEAT LED blinks at ZSM.
(LPC1) Low Pressure Control	Compressor CPR1 will not operate.	Open 48.3 kPa (7 PSIG) Close 22 PSIG.	Possible Cool Failure at J2-2 to Ground, 0 VAC. Cool LED blinks at ZSM.
(LPC2) Low Pressure Control	Compressor CPR2 will not operate.	Open 48.3 kPa (7 PSIG) Close 22 PSIG.	Possible Cool Failure at J2-3 to Ground, 0 VAC. Cool LED blinks at ZSM.
Internal Compressor Overload	Compressor CPR1 will not operate.	Normally closed, range varies by unit.	Cool Failure amp at LTB-8 to LTB-6 COOL LED blinks at ZSM.
Internal Compressor Overload	Compressor CPR2 will not operate.	Normally closed, amp range varies by unit.	Cool Failure at LTB-8 to LTB-6 COOL LED blinks at ZSM.
(HPC1) High Pressure Control	Compressor CPR1 will not operate.	Open 2.9 MPa (425 PSIG) Close 2.2 MPa (325 PSIG)	Cool Failure at LTB-8 to LTB-6 COOL LED blinks at ZSM.
(HPC2) High Pressure Control	Compressor CPR2 will not operate.	Open 2.9 MPa (425 PSIG) Close 2.2 MPa (325 PSIG)	Cool Failure at LTB-8 to LTB-6 COOL LED blinks at ZSM.

COMPONENT	FAILURE RESPONSE	NORMAL RANGE	DIAGNOSTIC
(CC1) Compressor Contactor 24 VAC coil	Compressor CPR will not operate.	1 Inrush = 50 to 75 VA Sealed = 5 to 6.5 VA.	Cool Failure at LTB-8 to LTB-6 COOL LED blinks at ZSM.
(CC2) Compressor Contactor 24 VAC coil	Compressor CPR will not operate.	2 Inrush = 50 to 75 VA Sealed = 5 to 6.5 VA.	Cool Failure at LTB-8 to LTB-6 COOL LED blinks at ZSM.
(CFS) Clogged Filter Switch *Any Generic Normally Open Switch*	This input does not have to be used, this will not change the normal operation of the unit, for indication only.	Normal Operation = 0 VAC measured between UCP J5-1 and Ground.	SERVICE LED comes on, 24 VAC measured between UCP J5-1 and Ground
AFF (Active Fan Failure Switch	Unit will not operate in any mode.	12.4 Pa (0.05" W.G.) contacts normally closed.	Service Failure at LTB-6 to LTB-10 service LED blinks at ZSM
(CTS) Coil Temperature Sensor	Defaults to 10 min. Defrost after each 30 min. compressor run time	- 48 to -79°C (-55 to 175°F) 680 K to 1.2 K Thermistor Chart p. 11.	Heat and Cool failure at LTB-7 to LTB-6 & LTB-8 to LTB-6 Heat and cool LED blinks at ZSM

Space Temperature Averaging with Microcontrol Zone Sensor Modules

Space Temperature Averaging is accomplished by wiring a number of Remote Sensors in series, with an equal number of parallel circuits.

For example, the fewest number of sensors required to accomplish Space Temperature Averaging is four. Two Remote Sensors are wired in series, they are then wired in parallel with the other two Remote Sensors, which are also wired in series. Any number squared, is the number of Remote Sensors required. EXAMPLE #1 is 2 squared, and EXAMPLE #2 is 3 squared, see examples below.

Example #1

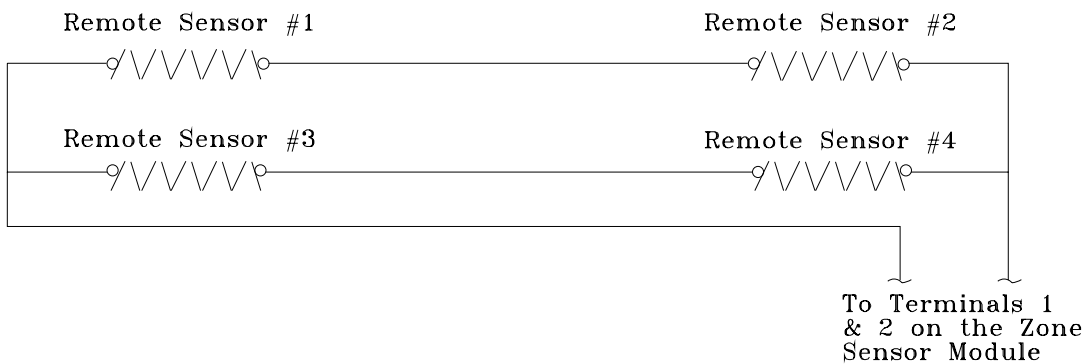

Example #2

